

BENEFICIARY ELIGIBLE MITIGATION ACTION CERTIFICATION

Beneficiary Nevada

Lead Agency Authorized to Act on Behalf of the Beneficiary Nevada Division of Environmental Protection
(Any authorized person with delegation of such authority to direct the Trustee delivered to the Trustee pursuant to a Delegation of Authority and Certificate of Incumbency)

Action Title:	DEMF, Southwest Airlines LAS AGSE Replacement
Beneficiary's Project ID:	NVDEMF 18-10 (DEP-S19-014)
Funding Request No.	<i>(sequential)</i> NVFRN 007
Request Type: (select one or more)	<input checked="" type="checkbox"/> Reimbursement <input checked="" type="checkbox"/> Advance <input type="checkbox"/> Other (specify): _____
Payment to be made to: (select one or more)	<input checked="" type="checkbox"/> Beneficiary <input checked="" type="checkbox"/> Other (specify): <u>Southwest Airlines</u>
Funding Request & Direction (Attachment A)	<input checked="" type="checkbox"/> Attached to this Certification <input type="checkbox"/> To be Provided Separately

SUMMARY

Eligible Mitigation Action	<input checked="" type="checkbox"/> Appendix D-2 item (specify): <u>Category 7-Airport Ground Support Equipment</u>	
Action Type	<input type="checkbox"/> Item 10 - DERA Option (5.2.12) (specify and attach DERA Proposal):	
Detailed Description of Mitigation Action Item Including Community and Air Quality Benefits (5.2.2):		
See pages 4-23 for detailed information on the mitigation action item including community and air quality benefits.		
Estimate of Anticipated NOx Reductions (5.2.3):		
It is anticipated that this project will mitigate 601.63 tons of NOx.		
Identification of Governmental Entity Responsible for Reviewing and Auditing Expenditures of Eligible Mitigation Action Funds to Ensure Compliance with Applicable Law (5.2.7.1):		
The Nevada Division of Environmental Protection		
Describe how the Beneficiary will make documentation publicly available (5.2.7.2).		
Please refer to pages 24-27 of this submittal for this description.		
Describe any cost share requirement to be placed on each NOx source proposed to be mitigated (5.2.8).		
Total project budget:	Project costs paid by the Trust:	Cost share requirement:
\$ 6,641,118.01	General Trust Costs	\$ 2,437,107.53
	\$ 3,655,661.29	\$ 548,349.19
Describe how the Beneficiary complied with subparagraph 4.2.8, related to notice to U.S. Government Agencies (5.2.9).		
NDEP sent emails to the representatives from the U.S. Department of the Interior and the U.S. Department of Agriculture listed in subparagraph 4.2.8 of the State Trust Agreement on February 23, 2018.		

If applicable, describe how the mitigation action will mitigate the impacts of NOx emissions on communities that have historically borne a disproportionate share of the adverse impacts of such emissions (5.2.10).

This equipment replacement project will be located in Clark County, Nevada. Clark County is an area of Nevada that has historically borne a disproportionate share of the state's air pollution burden.

ATTACHMENTS
(CHECK BOX IF ATTACHED)

- | | | |
|-------------------------------------|---------------------|---|
| <input checked="" type="checkbox"/> | Attachment A | Funding Request and Direction. |
| <input checked="" type="checkbox"/> | Attachment B | Eligible Mitigation Action Management Plan Including Detailed Budget and Implementation and Expenditures Timeline (5.2.4). |
| <input checked="" type="checkbox"/> | Attachment C | Detailed Plan for Reporting on Eligible Mitigation Action Implementation (5.2.11). |
| <input checked="" type="checkbox"/> | Attachment D | Detailed cost estimates from selected or potential vendors for each proposed expenditure exceeding \$25,000 (5.2.6). [Attach only if project involves vendor expenditures exceeding \$25,000.] |
| <input type="checkbox"/> | Attachment E | DERA Option (5.2.12). [Attach only if using DERA option.] |
| <input type="checkbox"/> | Attachment F | Attachment specifying amount of requested funding to be debited against each beneficiary's allocation (5.2.13). [Attach only if this is a joint application involving multiple beneficiaries.] |

CERTIFICATIONS

By submitting this application, the Lead Agency makes the following certifications:

- 1. This application is submitted on behalf of Beneficiary Nevada, and the person executing this certification has authority to make this certification on behalf of the Lead Agency and Beneficiary, pursuant to the Certification for Beneficiary Status filed with the Court.**
- 2. Beneficiary requests and directs that the Trustee make the payments described in this application and Attachment A to this Form.**
- 3. This application contains all information and certifications required by Paragraph 5.2 of the Trust Agreement, and the Trustee may rely on this application, Attachment A, and related certifications in making disbursements of trust funds for the aforementioned Project ID.**
- 4. Any vendors were or will be selected in accordance with a jurisdiction's public contracting law as applicable. (5.2.5)**
- 5. Beneficiary will maintain and make publicly available all documentation submitted in**

support of this funding request and all records supporting all expenditures of eligible mitigation action funds subject to applicable laws governing the publication of confidential business information and personally identifiable information. (5.2.7.2)

DATED: 12/27/18

Danilo Dragoni, PhD

[NAME]

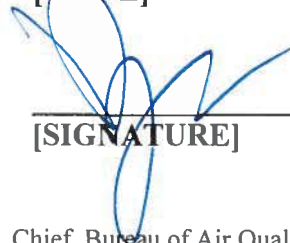

[SIGNATURE]

Chief, Bureau of Air Quality Planning

[TITLE]

Nevada Division of Environmental Protection

[LEAD AGENCY]

for

Nevada

[BENEFICIARY]

**DETAILED DESCRIPTION OF MITIGATION ACTION ITEM INCLUDING COMMUNITY
AND AIR QUALITY BENEFITS (5.2.2)**

The Nevada Division of Environmental Protection (NDEP) is submitting this Category 7 – Airport Ground Support Equipment Eligible Mitigation Action replacement project that will support the replacement and early-retirement of 109 pieces of diesel- and gasoline-powered airport ground support equipment (AGSE) owned and operated by Southwest Airlines located at the McCarran International Airport in Clark County, Nevada. Upon completion of the project, the permanent scrapping of these Non-Government owned AGSE for brand new all-electric replacements will provide a direct benefit to air quality.

The details regarding the individual units being replaced through this project as well as the replacement units are included on pages 5 through 16 of this submission. Most of the units being replaced are Tier 0 diesel- or unregulated gasoline-powered equipment. Southwest Airlines will have two airline mechanics dedicated to performing the scrapping requirements. This includes scrapping the engines by cutting the 3 inch holes in the engine blocks and transporting the equipment to a metals recycler located 5.5 miles from their AGSE shop where they will oversee the destruction of the chassis. The NDEP will work with Southwest Airlines on the scrapping of all 109 pieces of AGSE and will routinely coordinate with their staff for site visits and other routine updates to ensure a timely and efficient completion of this project.

The total, expected lifetime emissions reductions are provided in the table below. Emissions reductions for individual pieces of equipment are included on pages 17 and 18 of this submission. Emissions reductions were calculated using two methods based on the approach for alternative fuel-all-electric replacements that the NDEP identifies on page 26 our Beneficiary Mitigation Plan.¹ For the diesel-powered AGSE, emissions reductions were quantified using the EPA’s Diesel Emission Quantifier.² For the gasoline-powered AGSE, emissions reductions were quantified using a method based on the EPA’s NONROAD2008a Technical Reports³; the NDEP is including an explanation of this method of quantification with this submission and it begins on page 19.

Pollutant	Emissions Reductions
NOx	601.633 tons
PM _{2.5}	35.481 tons
CO	5,068.098 tons
HC	196.206 tons
CO ₂	109,886.464 tons

¹ Nevada’s Beneficiary Mitigation Plan can be found online at https://ndep.nv.gov/uploads/air-vw-bmp-docs/beneficiary_mitigation_plan.pdf.

² The EPA’s Diesel Emission Quantifier can be found online at <https://cfpub.epa.gov/quantifier/index.cfm?action=main.home>.

³ The EPA’s NONROAD2008a Technical Reports can be found online at <https://www.epa.gov/moves/nonroad-technical-reports>.

Existing Equipment/Engine Information						
Instructions/Units	Fleet Information					
Examples include baggage tug or tractor, belt loader, aircraft tug, etc.	Unit 1	Unit 2	Unit 3	Unit 4	Unit 3	Unit 4
What is the equipment's intended use?	Baggage Tug	Baggage Tug	Baggage Tug	Baggage Tug	Baggage Tug	Baggage Tug
Equipment Manufacturer	Tug	Tug	Tug	Tug	Tug	Tug
Equipment Model	M1A30	M1A30	MA30	M1A30	MA30	M1A30
Equipment Model Year	1999	1999	1999	1999	1999	1999
Engine Make	Deutz	Deutz	Deutz	Deutz	Deutz	Deutz
Engine Model	F4M2011	F4M1011F	F4M2011	F4M1011F	F4M2011	F4M1011F
Engine Model Year	2001	1999	2001	1999	2001	1999
Engine Serial Number	21505511	519874	11480942	00432605	11480942	00432605
Engine Horsepower	65	65	65	65	65	65
Annual Hours of Operation	542	344	305	964.5	305	964.5
Total Hours of Operation	10289	6536	5795	18325.5	5795	18325.5
Fuel Type	Diesel	Diesel	Diesel	Diesel	Diesel	Diesel
Annual Fuel Used (gallons)	748	475	421	1332	421	1332
If diesel-powered, what is the engine tier?	2	0	2	0	2	0
If gasoline-powered, what is the engine's NOx emission standard?						
Remaining Equipment Life (years)	11	11	11	11	11	11
Year in which Equipment would normally be retired/sold by the fleet owner if not for this grant.	2029	2029	2029	2029	2029	2029
Replacement/Repower Equipment/Engine Information						
Instructions/Units	Fleet Information					
	Unit 1	Unit 2	Unit 3	Unit 4	Unit 3	Unit 4
Equipment GVWR	NA	NA	NA	NA	NA	NA
Equipment Make	NA	NA	NA	NA	NA	NA
Equipment Model	NA	NA	NA	NA	NA	NA
Equipment Model Year	2018	2018	2018	2018	2018	2018
Engine Make	ABM Greiffenberger Motor	ABM Greiffenberger Motor	ABM Greiffenberger Motor	ABM Greiffenberger Motor	ABM Greiffenberger Motor	ABM Greiffenberger Motor
Engine Model	AC160LBR-6	AC160LBR-6	AC160LBR-6	AC160LBR-6	AC160LBR-6	AC160LBR-6
Engine Model Year	2018	2018	2018	2018	2018	2018
Fuel Type	Electric	Electric	Electric	Electric	Electric	Electric
Unit Replacement/Repower Cost	\$ 48,770.76	\$ 48,770.76	\$ 48,770.76	\$ 48,770.76	\$ 48,770.76	\$ 48,770.76

Unit 5	Unit 6	Unit 7	Unit 8	Unit 9	Unit 10	Unit 11	Unit 12	Unit 13	Unit 14
Baggage Tug	Baggage Tug	Baggage Tug	Baggage Tug	Baggage Tug	Baggage Tug	Baggage Tug	Baggage Tug	Baggage Tug	Baggage Tug
Jetline	Jetline	Tug	Tug	Jetline	Jetline	Jetline	Tug	Equi Tech	Tug
M-30	M-30	MIA30	MIA30	M-30	M-30	M-30	MIA30	M-30	MIA30
1994	1995	2001	2000	1994	1993	1995	2001	1986	2000
Ford Motor Co.	Ford Motor Co.	Deutz	Deutz	Deutz	Ford Motor Co.	Ford Motor Co.	Deutz	Deutz	Deutz
4.9L Carb	4.9L Carb	F4M2011	F4M1011F	BFM2012	4.9L Carb	4.9L Carb	F4M1011F	F4M2011	F4M1011F
1994	1995	2001	2000	2001	1993	1995	2000	2001	2000
1235	1239	00638364	447644	10098556	15513	15913 R-08-RA	1099539	10892276	860244
107	107	65	65	65	107	107	65	65	65
681	1016.5	1000.5	1035.5	570.5	608	633	806	607.5	653
16344	23379.5	17008.5	18639	13692	15200	14559	13702	19440	11754
Gas	Gas	Diesel	Diesel	Diesel	Gas	Gas	Diesel	Diesel	Diesel
NA	NA	1382	1430	788	NA	NA	1113	839	901
Unregulated	Unregulated	2	0	2	NA	NA	0	2	0
6	7	13	12	6	5	7	13	-2	12
2024	2025	2031	2030	2024	2023	2025	2031	2016	2030
Unit 5	Unit 6	Unit 7	Unit 8	Unit 9	Unit 10	Unit 11	Unit 12	Unit 13	Unit 14
NA	NA	NA	NA	NA	NA	NA	NA	NA	NA
NA	NA	NA	NA	NA	NA	NA	NA	NA	NA
NA	NA	NA	NA	NA	NA	NA	NA	NA	NA
2018	2018	2018	2018	2018	2018	2018	2018	2018	2018
ABM	ABM	ABM	ABM	ABM	ABM	ABM	ABM	ABM	ABM
Greiffenberger	Greiffenberger	Greiffenberger	Greiffenberger	Greiffenberger	Greiffenberger	Greiffenberger	Greiffenberger	Greiffenberger	Greiffenberger
Motor	Motor	Motor	Motor	Motor	Motor	Motor	Motor	Motor	Motor
ACI60LBR-6	ACI60LBR-6	ACI60LBR-6	ACI60LBR-6	ACI60LBR-6	ACI60LBR-6	ACI60LBR-6	ACI60LBR-6	ACI60LBR-6	ACI60LBR-6
2018	2018	2018	2018	2018	2018	2018	2018	2018	2018
Electric	Electric	Electric	Electric	Electric	Electric	Electric	Electric	Electric	Electric
\$ 48,770.76	\$ 48,770.76	\$ 48,770.76	\$ 48,770.76	\$ 48,770.76	\$ 48,770.76	\$ 48,770.76	\$ 48,770.76	\$ 48,770.76	\$ 48,770.76

Unit 15	Unit 16	Unit 17	Unit 18	Unit 19	Unit 20	Unit 21	Unit 22	Unit 23	Unit 24
Baggage Tug	Baggage Tug	Baggage Tug	Baggage Tug	Baggage Tug	Baggage Tug	Baggage Tug	Baggage Tug	Baggage Tug	Baggage Tug
Tug	Jetline	Tug	Jetline	Tug	Tug	Tug	Equi Tech	Tug	Tug
MIA30	M-30	MIA30	M-30	MIA30	MIA30	MIA30	M-30	MIA30	MIA30
1998	1995	2001	1995	2001	1998	1998	1986	1998	1998
Deutz	Deutz	Deutz	Ford Motor Co.	Deutz	Deutz	Deutz	Deutz	Deutz	Deutz
F4M1011F	F4M2011	F4M1011F	4.9L Carb	F4M1011F	F4M1011F	F4M1011F	BF4M1011F	F4M1011F	F4M1011F
1998	2001	2000	1995	2000	1998	1998	1998	1999	1999
00274912	1099540	569978	15909 R-08-RA	00638361	274929	21500064	288344	367408	643702
65	65	65	107	65	65	65	65	65	65
1014.5	1019	809	531	1250	1229	915.5	495.5	796	464.5
20290	23437	13753	12213	21250	24580	18310	15856	15920	9290
Diesel	Diesel	Diesel	Gas	Diesel	Diesel	Diesel	Diesel	Diesel	Diesel
1401	1407	1117		1725	1696	1264	685	1099	642
0	2	0	NA	0	0	0	0	0	0
			Unregulated						
10	7	13	7	13	10	10	-2	10	10
2028	2025	2031	2025	2031	2028	2028	2016	2028	2028
Unit 15	Unit 16	Unit 17	Unit 18	Unit 19	Unit 20	Unit 21	Unit 22	Unit 23	Unit 24
NA	NA	NA	NA	NA	NA	NA	NA	NA	NA
NA	NA	NA	NA	NA	NA	NA	NA	NA	NA
NA	NA	NA	NA	NA	NA	NA	NA	NA	NA
2018	2018	2018	2018	2018	2018	2018	2018	2018	2018
ABM	ABM	ABM	ABM	ABM	ABM	ABM	ABM	ABM	ABM
Greiffenberger	Greiffenberger	Greiffenberger	Greiffenberger	Greiffenberger	Greiffenberger	Greiffenberger	Greiffenberger	Greiffenberger	Greiffenberger
Motor	Motor	Motor	Motor	Motor	Motor	Motor	Motor	Motor	Motor
AC160LBR-6	AC160LBR-6	AC160LBR-6	AC160LBR-6	AC160LBR-6	AC160LBR-6	AC160LBR-6	AC160LBR-6	AC160LBR-6	AC160LBR-6
2018	2018	2018	2018	2018	2018	2018	2018	2018	2018
Electric	Electric	Electric	Electric	Electric	Electric	Electric	Electric	Electric	Electric
\$ 48,770.76	\$ 48,770.76	\$ 48,770.76	\$ 48,770.76	\$ 48,770.76	\$ 48,770.76	\$ 48,770.76	\$ 48,770.76	\$ 48,770.76	\$ 48,770.76

Unit 25	Unit 26	Unit 27	Unit 28	Unit 29	Unit 30	Unit 31	Unit 32	Unit 33	Unit 34
Baggage Tug	Baggage Tug	Baggage Tug	Baggage Tug	Baggage Tug	Baggage Tug	Baggage Tug	Baggage Tug	Baggage Tug	Baggage Tug
Tug	Tug	Tug	Tug	Tug	Tug	Tug	Tug	Tug	Tug
MIA30	MIA30	MIA30	MIA30	MIA30	MIA30	MIA30	MIA30	MIA30	MIA30
1998	1999	1999	2000	2000	2001	2001	2001	2001	2001
Deutz	Deutz	Deutz	Deutz	Deutz	Deutz	Deutz	Deutz	Deutz	Deutz
F4M1011F	F4M1011F	F4M1011F	F4M1011F	F4M1011F	F4M1011F	F4M1011F	F4M2011	F4M1011F	F4M1011F
1999	1999	1999	2001	2001	2001	2001	2001	2001	2001
21505510	10466485	00566204	00566200	00566192	00638358	00638389	00638379	00638386	00638380
65	65	65	65	65	65	65	65	65	65
1312	1031.5	1186	1032.5	738.5	801	1422.5	949	990.5	904.5
26240	20630	22534	18585	13293	13617	24182.5	16133	16838.5	15376.5
Diesel	Diesel	Diesel	Diesel	Diesel	Diesel	Diesel	Diesel	Diesel	Diesel
1811	1424	1637	1426	1020	1106	1964	1310	1368	1249
0	2	0	0	0	0	0	2	0	0
10	10	11	12	12	13	13	13	13	13
2028	2028	2029	2030	2030	2031	2031	2031	2031	2031

Unit 25	Unit 26	Unit 27	Unit 28	Unit 29	Unit 30	Unit 31	Unit 32	Unit 33	Unit 34
NA	NA	NA	NA	NA	NA	NA	NA	NA	NA
NA	NA	NA	NA	NA	NA	NA	NA	NA	NA
NA	NA	NA	NA	NA	NA	NA	NA	NA	NA
2018	2018	2018	2018	2018	2018	2018	2018	2018	2018
ABM	ABM	ABM	ABM	ABM	ABM	ABM	ABM	ABM	ABM
Greiffenberger	Greiffenberger	Greiffenberger	Greiffenberger	Greiffenberger	Greiffenberger	Greiffenberger	Greiffenberger	Greiffenberger	Greiffenberger
Motor	Motor	Motor	Motor	Motor	Motor	Motor	Motor	Motor	Motor
AC160LBR-6	AC160LBR-6	AC160LBR-6	AC160LBR-6	AC160LBR-6	AC160LBR-6	AC160LBR-6	AC160LBR-6	AC160LBR-6	AC160LBR-6
2018	2018	2018	2018	2018	2018	2018	2018	2018	2018
Electric	Electric	Electric	Electric	Electric	Electric	Electric	Electric	Electric	Electric
\$ 48,770.76	\$ 48,770.76	\$ 48,770.76	\$ 48,770.76	\$ 48,770.76	\$ 48,770.76	\$ 48,770.76	\$ 48,770.76	\$ 48,770.76	\$ 48,770.76

Unit 55	Unit 56	Unit 57	Unit 58	Unit 59	Unit 60	Unit 61	Unit 62	Unit 63	Unit 64
Baggage Tug	Baggage Tug	Baggage Tug	Baggage Tug	Baggage Tug	Baggage Tug	Baggage Tug	Baggage Tug	Baggage Tug	Baggage Tug
Tug	Tug	Tug	Wollard	Tug	Tug	Jetline	Jetline	Tug	Tug
MIA30	MIA30	MIA30	60	MIA30	MIA30	M-30	M-30	MIA30	MIA30
2005	2005	2005	2006	2007	2007	1996	1996	1998	1998
Deutz	Deutz	Deutz	Deutz	Deutz	Deutz	Deutz	Deutz	Deutz	Deutz
F4M2011	F4M2011	F4M2011	F4M2011	F4M2011	F4M2011	F4M2011	D2011L04	F4M1011F	F4M1011F
2005	2005	2005	2006	2007	2007	2007	2001	1998	1998
1089990	10120932	21500178	10123969	10466480	10468514	701	10881392	00252158	00274906
65	65	65	65	65	65	65	77	65	65
936.5	677.5	876.5	673.5	1185.5	860.5	960.5	650	410.5	654
12174.5	8807.5	11394.5	8082	13040.5	9465.5	21131	14300	8210	13080
Diesel	Diesel	Diesel	Diesel	Diesel	Diesel	Diesel	Diesel	Diesel	Diesel
1293	936	1211	930	1637	1188	1326	897	567	903
2	2	2	2	2	2	2	2	0	0
17	17	17	18	19	19	8	8	10	10
2035	2035	2035	2036	2037	2037	2026	2026	2028	2028

Unit 55	Unit 56	Unit 57	Unit 58	Unit 59	Unit 60	Unit 61	Unit 62	Unit 63	Unit 64
NA	NA	NA	NA	NA	NA	NA	NA	NA	NA
NA	NA	NA	NA	NA	NA	NA	NA	NA	NA
NA	NA	NA	NA	NA	NA	NA	NA	NA	NA
2018	2018	2018	2018	2018	2018	2018	2018	2018	2018
ABM	ABM	ABM	ABM	ABM	ABM	ABM	ABM	ABM	ABM
Greiffenberger	Greiffenberger	Greiffenberger	Greiffenberger	Greiffenberger	Greiffenberger	Greiffenberger	Greiffenberger	Greiffenberger	Greiffenberger
Motor	Motor	Motor	Motor	Motor	Motor	Motor	Motor	Motor	Motor
AC160LBR-6	AC160LBR-6	AC160LBR-6	AC160LBR-6	AC160LBR-6	AC160LBR-6	AC160LBR-6	AC160LBR-6	AC160LBR-6	AC160LBR-6
2018	2018	2018	2018	2018	2018	2018	2018	2018	2018
Electric	Electric	Electric	Electric	Electric	Electric	Electric	Electric	Electric	Electric
\$ 48,770.76	\$ 48,770.76	\$ 48,770.76	\$ 48,770.76	\$ 48,770.76	\$ 48,770.76	\$ 48,770.76	\$ 48,770.76	\$ 48,770.76	\$ 48,770.76

Unit 65	Unit 66	Unit 67	Unit 68	Unit 69	Unit 70	Unit 71	Unit 72	Unit 73	Unit 74
Baggage Tug	Baggage Tug	Baggage Tug	Belt Loader	Belt Loader	Belt Loader	Belt Loader	Belt Loader	Belt Loader	Belt Loader
Tug	Tug	Tug	Tug	Tug	Tug	Tug	Tug	Tug	Tug
MIA30	MIA30	MIA30	660	660	660	660	660	660	660
1996	2000	2000	2001	1996	1999	1996	1994	1996	1994
Deutz	Deutz	Deutz	Deutz	Ford Motor Co.	Deutz	Ford Motor Co.	Ford Motor Co.	Ford Motor Co.	Ford Motor Co.
F4M1011F	F4M2011	F4M1011F	F4M1011F	4.9L Carb	F4M1011F	4.9L Carb	4.9L Carb	4.9L Carb	4.9L Carb
1996	2001	2000	2001	1996	1999	1996	1994	1996	1994
00838271	21504170	00443777	00569970	21177 E-03-R6	00374525	13451M-24RC	11614H-07-RA	01906 B-05-RK	08923 C-21-RA
65	65	65	65	107	65	107	107	107	107
589	642	499.5	1279.333333	1371.333333	1154.333333	1359.333333	1138	1358.333333	1438
12958	11556	8991	23171	33924	24548	31284	31680	31548	37296
Diesel	Diesel	Diesel	Diesel	Gas	Diesel	Gas	Gas	Gas	Gas
813	886	690	1622		1464				
0	2	0	0	NA	0	NA	NA	NA	NA
				Unregulated		Unregulated	Unregulated	Unregulated	Unregulated
8	12	12	12	7	10	7	5	7	5
2026	2030	2030	2030	2025	2028	2025	2023	2025	2023
Unit 65	Unit 66	Unit 67	Unit 68	Unit 69	Unit 70	Unit 71	Unit 72	Unit 73	Unit 74
NA	NA	NA	NA	NA	NA	NA	NA	NA	NA
NA	NA	NA	NA	NA	NA	NA	NA	NA	NA
NA	NA	NA	NA	NA	NA	NA	NA	NA	NA
2018	2018	2018	2018	2018	2018	2018	2018	2018	2018
ABM	ABM	ABM	C.F.R.	C.F.R.	C.F.R.	C.F.R.	C.F.R.	C.F.R.	C.F.R.
Greiffenberger	Greiffenberger	Greiffenberger	Greiffenberger	Greiffenberger	Greiffenberger	Greiffenberger	Greiffenberger	Greiffenberger	Greiffenberger
Motor	Motor	Motor	Motor	Motor	Motor	Motor	Motor	Motor	Motor
AC160LBR-6	AC160LBR-6	AC160LBR-6	AM200.0204	AM200.0204	AM200.0204	AM200.0204	AM200.0204	AM200.0204	AM200.0204
2018	2018	2018	2018	2018	2018	2018	2018	2018	2018
Electric	Electric	Electric	Electric	Electric	Electric	Electric	Electric	Electric	Electric
\$ 48,770.76	\$ 48,770.76	\$ 48,770.76	\$ 67,264.95	\$ 67,264.95	\$ 67,264.95	\$ 67,264.95	\$ 67,264.95	\$ 67,264.95	\$ 67,264.95

Unit 85	Unit 86	Unit 87	Unit 88	Unit 89	Unit 90	Unit 91	Unit 92	Unit 93	Unit 94
Belt Loader	Belt Loader	Belt Loader	Belt Loader	Belt Loader	Belt Loader	Belt Loader	Belt Loader	Belt Loader	Belt Loader
Tug	Tug	Tug	Tug	Tug	Tug	Tug	Tug	Tug	Tug
660	660	660	660	660	660	660	660	660	660
1995	1996	1994	1993	1994	1994	1995	2001	1995	1994
Ford Motor Co.	Ford Motor Co.	Ford Motor Co.	Ford Motor Co.	Ford Motor Co.	Ford Motor Co.	Ford Motor Co.	Deutz	Ford Motor Co.	Ford Motor Co.
4.9L Carb	4.9L Carb	4.9L Carb	4.9L Carb	4.9L Carb	4.9L Carb	4.9L Carb	F4M1011F	4.9L Carb	4.9L Carb
1995	1996	1994	1993	1994	1994	1995	2001	1995	1994
20618S-31-RC	04708B-28-RK	08460C-14-RA	01923B-01-RL	08932 C21RA	08446C-14-RA	20619S-31-R6	00605559	Missing	08445G-14-RA
107	107	107	107	107	107	107	65	107	107
1358.666667	1133.666667	1078.333333	1383.666667	1310.666667	1223	1243	1322	1300	1238.666667
34661	31680	28200	39175	32136	32712	35742	24242	33534	37008
Gas	Gas	Gas	Gas	Gas	Gas	Gas	Diesel	Gas	Gas
							1677		
NA	NA	NA	NA	NA	NA	NA	0	NA	NA
Unregulated	Unregulated	Unregulated	Unregulated	Unregulated	Unregulated	Unregulated		Unregulated	Unregulated
6	7	5	4	5	5	6	12	6	5
2024	2025	2023	2022	2023	2023	2024	2030	2024	2023
Unit 85	Unit 86	Unit 87	Unit 88	Unit 89	Unit 90	Unit 91	Unit 92	Unit 93	Unit 94
NA	NA	NA	NA	NA	NA	NA	NA	NA	NA
NA	NA	NA	NA	NA	NA	NA	NA	NA	NA
NA	NA	NA	NA	NA	NA	NA	NA	NA	NA
2018	2018	2018	2018	2018	2018	2018	2018	2018	2018
C.F.R.	C.F.R.	C.F.R.	C.F.R.	C.F.R.	C.F.R.	C.F.R.	C.F.R.	C.F.R.	C.F.R.
AM200.0204	AM200.0204	AM200.0204	AM200.0204	AM200.0204	AM200.0204	AM200.0204	AM200.0204	AM200.0204	AM200.0204
2018	2018	2018	2018	2018	2018	2018	2018	2018	2018
Electric	Electric	Electric	Electric	Electric	Electric	Electric	Electric	Electric	Electric
\$ 67,264.95	\$ 67,264.95	\$ 67,264.95	\$ 67,264.95	\$ 67,264.95	\$ 67,264.95	\$ 67,264.95	\$ 67,264.95	\$ 67,264.95	\$ 67,264.95

Unit 95	Unit 96	Unit 97	Unit 98	Unit 99	Unit 100	Unit 101	Unit 102	Unit 103	Unit 104
Belt Loader	Belt Loader	Belt Loader	Belt Loader	Belt Loader	Belt Loader	Belt Loader	Belt Loader	Belt Loader	Belt Loader
Tug	Tug	Tug	Tug	Tug	Tug	Tug	Tug	Tug	Tug
660	660	660	660	660	660	660	660	660	660
1999	1994	1996	2001	1994	1995	1994	1996	1994	1993
Deutz	Ford Motor Co.	Ford Motor Co.	Deutz	Ford Motor Co.	Ford Motor Co.	Ford Motor Co.	Ford Motor Co.	Ford Motor Co.	Ford Motor Co.
F4M101F	4.9L Carb	4.9L Carb	F4M101F	4.9L Carb	4.9L Carb	4.9L Carb	4.9L Carb	4.9L Carb	4.9L Carb
1999	1994	1996	2001	1994	1995	1994	1996	1994	1993
XDZXL029013	12769M-25-RA	04703 B-28-RK	569301	07138C-21-RB	00145 C-04-RK	03387L-08-RA	AFI-J12064	Missing	16034F-10-RB
65	107	107	65	107	107	107	107	107	107
1214	1299	1359.333333	1239.666667	1341.333333	1446.333333	1401	1262.333333	1248.666667	1316
22838	33552	33792	23987	35112	36846	36720	29612	34200	37475
Diesel	Gas	Gas	Diesel	Gas	Gas	Gas	Gas	Gas	Gas
1540			1573						
0	NA	NA	0	NA	NA	NA	NA	NA	NA
	Unregulated	Unregulated		Unregulated	Unregulated	Unregulated	Unregulated	Unregulated	Unregulated
10	5	7	12	5	6	5	7	5	4
2028	2023	2025	2030	2023	2024	2023	2025	2023	2022
Unit 95	Unit 96	Unit 97	Unit 98	Unit 99	Unit 100	Unit 101	Unit 102	Unit 103	Unit 104
NA	NA	NA	NA	NA	NA	NA	NA	NA	NA
NA	NA	NA	NA	NA	NA	NA	NA	NA	NA
NA	NA	NA	NA	NA	NA	NA	NA	NA	NA
2018	2018	2018	2018	2018	2018	2018	2018	2018	2018
C.F.R.	C.F.R.	C.F.R.	C.F.R.	C.F.R.	C.F.R.	C.F.R.	C.F.R.	C.F.R.	C.F.R.
AM200.0204	AM200.0204	AM200.0204	AM200.0204	AM200.0204	AM200.0204	AM200.0204	AM200.0204	AM200.0204	AM200.0204
2018	2018	2018	2018	2018	2018	2018	2018	2018	2018
Electric	Electric	Electric	Electric	Electric	Electric	Electric	Electric	Electric	Electric
\$ 67,264.95	\$ 67,264.95	\$ 67,264.95	\$ 67,264.95	\$ 67,264.95	\$ 67,264.95	\$ 67,264.95	\$ 67,264.95	\$ 67,264.95	\$ 67,264.95

Unit 105	Unit 106	Unit 107	Unit 108	Unit 109
Belt Loader	Belt Loader	Belt Loader	Belt Loader	Belt Loader
Tug	Tug	Tug	Tug	Tug
660	660	660	660	660
1995	1994	1994	1995	1994
Ford Motor Co.	Ford Motor Co.	Ford Motor Co.	Ford Motor Co.	Ford Motor Co.
4.9L Carb	4.9L Carb	4.9L Carb	4.9L Carb	4.9L Carb
1995	1994	1994	1995	1994
Missing	11618H-07-RA	19892	03528 B-27-RC	11614-H-07RA
107	107	107	107	107
1194	1400.666667	1259	1204.333333	1324
35328	37584	36288	28520	32688
Gas	Gas	Gas	Gas	Gas
NA	NA	NA	NA	NA
Unregulated	Unregulated	Unregulated	Unregulated	Unregulated
6	5	5	6	5
2024	2023	2023	2024	2023
Unit 105				
NA	NA	NA	NA	NA
NA	NA	NA	NA	NA
NA	NA	NA	NA	NA
2018	2018	2018	2018	2018
C.F.R.	C.F.R.	C.F.R.	C.F.R.	C.F.R.
AM200.0204	AM200.0204	AM200.0204	AM200.0204	AM200.0204
2018	2018	2018	2018	2018
Electric	Electric	Electric	Electric	Electric
\$ 67,264.95	\$ 67,264.95	\$ 67,264.95	\$ 67,264.95	\$ 67,264.95

Unit	Unit Cost	Requested Amount	DEQ or Gas	Emissions Reductions (tons)				
				NOx	PM2.5	CO	HC	CO2
Unit 1	\$ 48,770.76	\$ 29,262.46	DEQ	3.568	0.222	1.199	0.240	356.646
Unit 2	\$ 48,770.76	\$ 29,262.46	DEQ	3.057	0.130	0.803	0.186	322.863
Unit 3	\$ 48,770.76	\$ 29,262.46	DEQ	2.955	0.110	0.722	0.175	316.181
Unit 4	\$ 48,770.76	\$ 29,262.46	DEQ	4.715	0.534	2.197	0.363	428.916
Unit 5	\$ 48,770.76	\$ 29,262.46	GAS	4.088	0.110	58.044	2.069	1,029.373
Unit 6	\$ 48,770.76	\$ 29,262.46	GAS	6.740	0.164	96.471	3.489	1,548.696
Unit 7	\$ 48,770.76	\$ 29,262.46	DEQ	5.274	0.627	2.622	0.422	466.199
Unit 8	\$ 48,770.76	\$ 29,262.46	DEQ	5.151	0.630	2.552	0.409	457.131
Unit 9	\$ 48,770.76	\$ 29,262.46	DEQ	2.982	0.136	0.766	0.179	317.271
Unit 10	\$ 48,770.76	\$ 29,262.46	GAS	3.269	0.098	45.942	1.608	911.735
Unit 11	\$ 48,770.76	\$ 29,262.46	GAS	4.197	0.102	60.075	2.173	964.412
Unit 12	\$ 48,770.76	\$ 29,262.46	DEQ	4.653	0.466	2.089	0.355	426.858
Unit 13	\$ 48,770.76	\$ 29,262.46	DEQ	2.188	0.013	0.173	0.096	264.081
Unit 14	\$ 48,770.76	\$ 29,262.46	DEQ	4.017	0.318	1.561	0.288	385.717
Unit 15	\$ 48,770.76	\$ 29,262.46	DEQ	4.618	0.541	2.149	0.354	421.693
Unit 16	\$ 48,770.76	\$ 29,262.46	DEQ	3.881	0.353	1.520	0.274	374.883
Unit 17	\$ 48,770.76	\$ 29,262.46	DEQ	4.663	0.468	2.098	0.356	427.443
Unit 18	\$ 48,770.76	\$ 29,262.46	GAS	3.521	0.086	50.394	1.823	809.009
Unit 19	\$ 48,770.76	\$ 29,262.46	DEQ	6.105	0.917	3.412	0.513	516.363
Unit 20	\$ 48,770.76	\$ 29,262.46	DEQ	5.168	0.733	2.673	0.414	454.881
Unit 21	\$ 48,770.76	\$ 29,262.46	DEQ	4.368	0.461	1.919	0.327	406.281
Unit 22	\$ 48,770.76	\$ 29,262.46	DEQ	2.188	0.013	0.173	0.096	264.081
Unit 23	\$ 48,770.76	\$ 29,262.46	DEQ	4.064	0.364	1.638	0.294	387.719
Unit 24	\$ 48,770.76	\$ 29,262.46	DEQ	3.263	0.173	0.969	0.208	336.306
Unit 25	\$ 48,770.76	\$ 29,262.46	DEQ	5.373	0.790	2.853	0.436	467.818
Unit 26	\$ 48,770.76	\$ 29,262.46	DEQ	4.639	0.508	2.126	0.355	424.281
Unit 27	\$ 48,770.76	\$ 29,262.46	DEQ	5.333	0.737	2.773	0.430	466.660
Unit 28	\$ 48,770.76	\$ 29,262.46	DEQ	5.133	0.609	2.520	0.407	456.591
Unit 29	\$ 48,770.76	\$ 29,262.46	DEQ	4.263	0.370	1.760	0.313	401.781
Unit 30	\$ 48,770.76	\$ 29,262.46	DEQ	4.632	0.449	2.059	0.353	425.834
Unit 31	\$ 48,770.76	\$ 29,262.46	DEQ	6.670	1.092	3.929	0.574	551.316
Unit 32	\$ 48,770.76	\$ 29,262.46	DEQ	5.105	0.578	2.473	0.404	455.669
Unit 33	\$ 48,770.76	\$ 29,262.46	DEQ	5.242	0.617	2.593	0.418	464.151
Unit 34	\$ 48,770.76	\$ 29,262.46	DEQ	4.963	0.539	2.348	0.388	446.748
Unit 35	\$ 48,770.76	\$ 29,262.46	DEQ	6.101	0.890	3.383	0.512	517.094
Unit 36	\$ 48,770.76	\$ 29,262.46	DEQ	7.020	1.224	4.273	0.612	572.084
Unit 37	\$ 48,770.76	\$ 29,262.46	DEQ	2.974	0.134	0.759	0.178	316.731
Unit 38	\$ 48,770.76	\$ 29,262.46	GAS	5.655	0.152	80.290	2.862	1,423.890
Unit 39	\$ 48,770.76	\$ 29,262.46	DEQ	3.948	0.442	1.653	0.284	376.750
Unit 40	\$ 48,770.76	\$ 29,262.46	DEQ	2.877	0.109	0.676	0.168	310.623
Unit 41	\$ 48,770.76	\$ 29,262.46	GAS	3.356	0.090	47.646	1.699	844.963
Unit 42	\$ 48,770.76	\$ 29,262.46	GAS	2.553	0.048	37.175	1.384	467.864
Unit 43	\$ 48,770.76	\$ 29,262.46	GAS	12.601	0.222	184.218	6.907	2,167.159
Unit 44	\$ 48,770.76	\$ 29,262.46	GAS	3.710	0.065	54.237	2.034	638.047
Unit 45	\$ 48,770.76	\$ 29,262.46	GAS	1.786	0.032	26.117	0.979	307.237
Unit 46	\$ 48,770.76	\$ 29,262.46	GAS	9.174	0.162	134.123	5.029	1,577.830
Unit 47	\$ 48,770.76	\$ 29,262.46	DEQ	1.148	0.149	0.873	0.191	239.961
Unit 48	\$ 48,770.76	\$ 29,262.46	DEQ	3.644	0.306	1.331	0.249	359.324
Unit 49	\$ 48,770.76	\$ 29,262.46	GAS	3.887	0.105	55.189	1.967	978.736
Unit 50	\$ 48,770.76	\$ 29,262.46	GAS	4.022	0.108	57.107	2.036	1,012.746
Unit 51	\$ 48,770.76	\$ 29,262.46	GAS	6.234	0.168	88.515	3.155	1,569.756
Unit 52	\$ 48,770.76	\$ 29,262.46	GAS	8.815	0.215	126.176	4.564	2,025.570
Unit 53	\$ 48,770.76	\$ 29,262.46	GAS	8.152	0.198	116.685	4.220	1,873.214
Unit 54	\$ 48,770.76	\$ 29,262.46	DEQ	3.911	0.362	1.546	0.278	376.694

Unit 55	\$ 48,770.76	\$ 29,262.46	DEQ	5.239	0.330	3.019	0.370	511.367
Unit 56	\$ 48,770.76	\$ 29,262.46	DEQ	4.388	0.211	2.150	0.291	443.091
Unit 57	\$ 48,770.76	\$ 29,262.46	DEQ	5.041	0.301	2.811	0.351	495.686
Unit 58	\$ 48,770.76	\$ 29,262.46	DEQ	4.501	0.215	2.237	0.301	452.406
Unit 59	\$ 48,770.76	\$ 29,262.46	DEQ	6.510	0.481	4.246	0.485	613.989
Unit 60	\$ 48,770.76	\$ 29,262.46	DEQ	5.312	0.304	3.006	0.375	518.016
Unit 61	\$ 48,770.76	\$ 29,262.46	DEQ	3.658	0.157	1.522	0.227	383.421
Unit 62	\$ 48,770.76	\$ 29,262.46	DEQ	1.632	0.239	1.253	0.245	302.739
Unit 63	\$ 48,770.76	\$ 29,262.46	DEQ	3.136	0.150	0.871	0.195	327.869
Unit 64	\$ 48,770.76	\$ 29,262.46	DEQ	3.720	0.280	1.349	0.257	365.669
Unit 65	\$ 48,770.76	\$ 29,262.46	DEQ	3.547	0.315	1.574	0.320	337.252
Unit 66	\$ 48,770.76	\$ 29,262.46	DEQ	3.981	0.304	1.525	0.283	383.691
Unit 67	\$ 48,770.76	\$ 29,262.46	DEQ	3.576	0.221	1.202	0.241	357.231
Unit 68	\$ 67,264.95	\$ 40,358.97	DEQ	5.880	0.850	3.211	0.488	483.051
Unit 69	\$ 67,264.95	\$ 40,358.97	GAS	8.990	0.214	128.902	4.676	2,023.500
Unit 70	\$ 67,264.95	\$ 40,358.97	DEQ	4.964	0.643	2.459	0.391	428.781
Unit 71	\$ 67,264.95	\$ 40,358.97	GAS	8.911	0.212	127.774	4.635	2,005.793
Unit 72	\$ 67,264.95	\$ 40,358.97	GAS	6.033	0.178	84.958	2.984	1,651.896
Unit 73	\$ 67,264.95	\$ 40,358.97	GAS	8.904	0.212	127.680	4.632	2,004.318
Unit 74	\$ 67,264.95	\$ 40,358.97	GAS	7.624	0.224	107.355	3.770	2,087.370
Unit 75	\$ 67,264.95	\$ 40,358.97	DEQ	5.892	0.853	3.223	0.489	483.727
Unit 76	\$ 67,264.95	\$ 40,358.97	DEQ	5.893	0.920	3.292	0.491	481.758
Unit 77	\$ 67,264.95	\$ 40,358.97	GAS	8.826	0.210	126.552	4.591	1,986.611
Unit 78	\$ 67,264.95	\$ 40,358.97	GAS	7.898	0.233	111.212	3.906	2,162.368
Unit 79	\$ 67,264.95	\$ 40,358.97	GAS	5.880	0.173	82.793	2.908	1,609.800
Unit 80	\$ 67,264.95	\$ 40,358.97	GAS	6.982	0.206	98.322	3.453	1,911.729
Unit 81	\$ 67,264.95	\$ 40,358.97	GAS	6.951	0.205	97.874	3.437	1,903.019
Unit 82	\$ 67,264.95	\$ 40,358.97	GAS	8.675	0.206	124.390	4.513	1,952.673
Unit 83	\$ 67,264.95	\$ 40,358.97	GAS	6.131	0.181	86.327	3.032	1,678.509
Unit 84	\$ 67,264.95	\$ 40,358.97	GAS	6.412	0.189	90.284	3.171	1,755.442
Unit 85	\$ 67,264.95	\$ 40,358.97	GAS	8.055	0.212	114.572	4.098	1,988.510
Unit 86	\$ 67,264.95	\$ 40,358.97	GAS	7.432	0.177	106.562	3.866	1,672.806
Unit 87	\$ 67,264.95	\$ 40,358.97	GAS	5.717	0.168	80.504	2.827	1,565.285
Unit 88	\$ 67,264.95	\$ 40,358.97	GAS	6.468	0.216	89.917	3.083	1,991.901
Unit 89	\$ 67,264.95	\$ 40,358.97	GAS	6.949	0.205	97.849	3.437	1,902.535
Unit 90	\$ 67,264.95	\$ 40,358.97	GAS	6.484	0.191	91.304	3.207	1,775.280
Unit 91	\$ 67,264.95	\$ 40,358.97	GAS	7.369	0.194	104.818	3.749	1,819.224
Unit 92	\$ 67,264.95	\$ 40,358.97	DEQ	6.012	0.895	3.337	0.503	490.477
Unit 93	\$ 67,264.95	\$ 40,358.97	GAS	7.707	0.203	109.625	3.921	1,902.647
Unit 94	\$ 67,264.95	\$ 40,358.97	GAS	6.567	0.193	92.474	3.248	1,798.022
Unit 95	\$ 67,264.95	\$ 40,358.97	DEQ	5.119	0.697	2.606	0.408	437.331
Unit 96	\$ 67,264.95	\$ 40,358.97	GAS	6.887	0.203	96.978	3.406	1,885.600
Unit 97	\$ 67,264.95	\$ 40,358.97	GAS	8.911	0.212	127.774	4.635	2,005.793
Unit 98	\$ 67,264.95	\$ 40,358.97	DEQ	5.760	0.809	3.098	0.475	476.437
Unit 99	\$ 67,264.95	\$ 40,358.97	GAS	7.111	0.209	100.138	3.517	1,947.051
Unit 100	\$ 67,264.95	\$ 40,358.97	GAS	8.575	0.226	121.965	4.362	2,116.817
Unit 101	\$ 67,264.95	\$ 40,358.97	GAS	7.428	0.219	104.593	3.673	2,033.661
Unit 102	\$ 67,264.95	\$ 40,358.97	GAS	8.275	0.197	118.656	4.305	1,862.663
Unit 103	\$ 67,264.95	\$ 40,358.97	GAS	6.620	0.195	93.220	3.274	1,812.538
Unit 104	\$ 67,264.95	\$ 40,358.97	GAS	6.152	0.205	85.520	2.932	1,894.490
Unit 105	\$ 67,264.95	\$ 40,358.97	GAS	7.079	0.186	100.686	3.601	1,747.508
Unit 106	\$ 67,264.95	\$ 40,358.97	GAS	7.426	0.219	104.568	3.672	2,033.177
Unit 107	\$ 67,264.95	\$ 40,358.97	GAS	6.675	0.197	93.992	3.301	1,827.537
Unit 108	\$ 67,264.95	\$ 40,358.97	GAS	7.140	0.188	101.557	3.632	1,762.632
Unit 109	\$ 67,264.95	\$ 40,358.97	GAS	7.019	0.207	98.844	3.471	1,921.890
Total	\$ 6,092,768.82	\$ 3,655,661.29		601.633	35.481	5,068.098	196.206	109,886.464

**EPA's NONROAD Method of Quantifying Vehicle/Equipment Emissions and
How this Method is Applied to the Volkswagen Environmental Mitigation Trust Agreement for State
Beneficiaries Eligible Mitigation Action Category 7: Airport Ground Support Equipment**

Overview

This document has been prepared to help with the quantification of emissions associated with gasoline-powered airport ground support equipment (AGSE). It was developed using the Environmental Protection Agency's (EPA) NONROAD2008a Technical Reports.¹ It provides a method for individuals not experienced with the EPA's Motor Vehicle Emission Simulator (MOVES) model to quantify emissions associated with individual pieces of gasoline-powered equipment.

Method

NONROAD2008a quantifies emissions for spark-ignition (gasoline-powered) engines using the following equation² (the equation is essentially the same for diesel-powered engines, but there are some small differences relating to the difference in the nature of diesel fuel):

$$Emissions = Pop * Power * LF * A * EF * TAF$$

Where Pop is defined as engine population

Power is defined as average engine horsepower (hp)

LF is defined as Load Factor (fraction of available power used)

A is defined as Activity, or cumulative hours of use per year (hrs/yr)

EF is defined as the Emission Factor (g/hp-hr)

TAF is defined as the Transient Adjustment Factor

The various technical papers used to describe NONROAD2008a provide Load Factors, Activity, and Emissions Factors for various engines (2-stroke gasoline, 4-stroke gasoline, and diesel), engine horsepowers, and pollutants (HC, CO, NO_x, and PM).

Emissions Factors³ are determined using the following equation:

$$EF_{aged} = EF_0 * DF$$

Where EF_{aged} is defined as the emission factor for an aged engine (g/hp-hr)

EF₀ is defined as the zero-hour emission factor of a new engine (g/hp-hr)

DF is defined as the Deterioration Factor

And the Deterioration Factor⁴ is determined using one of the two equations:

¹ EPA's Nonroad Technical Reports are available at <https://www.epa.gov/moves/nonroad-technical-reports>.

² EPA NR-005d. Median Life, Annual Activity, and Load Factor Values for Nonroad Engine Emissions Modeling Report No. NR-005d, July 2010. p. 1.

³ EPA NR-011d. Nonroad Spark-Ignition Engine Emission Deterioration Factors Report No. NR-011d, July 2010. p. 3.

⁴ Ibid 3.

$$DF = 1 + A * (Age\ Factor)^b \quad \text{for Age Factor} \leq 1$$

$$DF = 1 + A \quad \text{for Age Factor} > 1$$

$$\text{Where } Age\ Factor = \frac{(Cumulative\ Hours * Load\ Factor)}{Median\ Life\ at\ full\ load\ (hrs)}$$

A is defined as the Deterioration Factor for a given pollutant and technology type

b is defined as the Age Exponent for a given technology type

Once again, the EPA, in their NONROAD2008a technical papers, provide zero-hour emission factors for new engines (both unregulated and regulated), Age Factors, Deterioration Factors for various pollutants (HC, CO, NOx, and PM), and Age Exponents.

With the above equations and NONROAD2008a inputs, emissions can be quantified for both gasoline- and diesel-powered AGSE. The inputs are provided below for 4-stroke gasoline and diesel-powered AGSE for illustrative purposes. In the examples portion of this document there is also a case where the same diesel inputs are used in the EPA's Diesel Emission Quantifier (DEQ) to compare results and ensure that this is a sound method for quantifying emissions.⁵

Inputs

Table 1: Load Factor and Average Activity (EPA NR-005d)⁶

Description	Load Factor (fraction of power)	Activity (hrs/yr)
4-Stroke Gasoline Airport GSE	0.56	681
Diesel Airport GSE	0.59	732

Table 2: Median Life at full load for various horsepower and engine technology types (EPA NR-005d)⁷

Description	Horsepower Range	Median Life (hrs)
4-Stroke Gasoline	51-100	3,000
	101-175	3,000
Diesel	101-175	4,667
	176-300	4,667

⁵ The EPA's Diesel Emission Quantifier can be accessed at <https://cfpub.epa.gov/quantifier/index.cfm?action=main.home>.

⁶ Ibid 2. Table 10; p. 16. Appendix A; p. A4.

⁷ Ibid 2. Table 1 and Table 2; p. 3.

Table 3: Deterioration Factors and Age Exponents for 4-stroke gasoline-powered engines >25hp (EPA NR-011d)⁸

Emission Standard	A				b
	HC	CO	NOx	PM	
Uncontrolled	0.26	0.35	0.03	0.26	1
Phase 1	0.64	0.36	0.15	0.26	1
Phase 2	0.64	0.36	0.15	0.26	1

Table 4: Deterioration Factors and Age Exponents for diesel-powered engines (EPA NR-009d)⁹

Pollutant	Relative Deterioration Factor (A)			
	Base/Tier 0	Tier 1	Tier 2	Tier 3+
HC	0.047	0.036	0.034	0.027
CO	0.185	0.101	0.101	0.151
NOx	0.024	0.024	0.009	0.008
PM	0.473	0.473	0.473	0.473

b=1 for diesel nonroad engines

Table 5: Zero-hour Emissions Factors and Brake Specific Fuel Consumption (BSFC) for gasoline-powered engines >25hp (EPA NR-010f)¹⁰

Emission Standard	HC g/hp-hr	CO g/hp-hr	NOx g/hp-hr	PM g/hp-hr	BSFC lb/hp-hr
Uncontrolled	3.85	107.23	8.43	0.06	0.605
Phase 1	0.59	29.86	1.51	0.06	0.484
Phase 2	0.27	11.94	0.69	0.06	0.484

⁸ Ibid 3. Table 6; p. 9.

⁹ EPA NR-009d. Exhaust and Crankcase Emission Factors for Nonroad Engine Modeling — Compression-Ignition Report No. NR-009d, July 2010. Table A6; p. A16.

¹⁰ EPA NR-010f. Exhaust Emission Factors for Nonroad Engine Modeling — Spark-Ignition Report No. NR-010f, July 2010. Table 6; p. 8.

Table 6: Zero-hour Emission Factors and BSFC for diesel-powered AGSE engines (EPA NR-009d)¹¹

Engine Power Hp	Technology Type	BSFC lb/hp-hr	Emission Factors (g/hp-hr)			
			HC	CO	NOx	PM
101-175	Base*	0.367	0.68	2.7	8.38	0.402
	Tier 0		0.68	2.7	8.38	0.402
	Tier 1		0.3384	0.8667	5.6523	0.2799
	Tier 2		0.3384	0.8667	4.1	0.18
	Tier 3		0.1836	0.8667	2.5	0.22
	Tier 4		0.1314	0.087	2.5	0.0092
	Tier 4N		0.1314	0.087	0.276	0.0092
176-300	Base*	0.367	0.68	2.7	8.38	0.402
	Tier 0		0.68	2.7	8.38	0.402
	Tier 1		0.3085	0.7475	5.5772	0.2521
	Tier 2		0.3085	0.7475	4	0.1316
	Tier 3		0.1836	0.7475	2.5	0.15
	Tier 4		0.1314	0.075	2.5	0.0092
	Tier 4N		0.1314	0.075	0.276	0.0092

*Note that NR-009d includes more specific emissions information for certain nonroad Base engines (Table C2 of document and begins on page 49 of pdf)

Table 7: Transient Adjustment Factors for gasoline-powered engines (EPA NR-010f)¹²

Emission Standard	HC g/hp-hr	CO g/hp-hr	NOx g/hp-hr	PM g/hp-hr	BSFC Lb/hp-hr
Uncontrolled	1.3	1.45	1	1	1
Phase 1	1.7	1.7	1.4	1	1
Phase 2	1	1	1	1	1

Table 8: Transient Adjustment Factors for diesel-powered AGSE engines (EPA NR-009d)¹³

Emission Standard	HC g/hp-hr	CO g/hp-hr	NOx g/hp-hr	PM g/hp-hr	BSFC Lb/hp-hr
Base	1.05	1.53	0.95	1.23	1.01
Tier 0	1.05	1.53	0.95	1.23	1.01
Tier 1	1.05	1.53	0.95	1.23	1.01
Tier 2	1.05	1.53	0.95	1.23	1.01
Tier 3	1.05	1.53	1.04	1.47	1.01

Examples

Assume a 1995 engine model year 107 hp gasoline-powered GSE engine with 13,415.7 cumulative hours and all EPA NONROAD2008a defaults for every other input. What are the estimated NOx emissions?

¹¹ Ibid 9. Table A4; p. A10.

¹² Ibid 10. Table 14; p. 16.

¹³ Ibid 9. Table A5; p. A15.

Test Age Factor:

$$Age\ Factor = \frac{(13,415.7 * 0.56)}{3,000} = 2.5$$

Because the Age Factor is greater than 1, we determine the Deterioration Factor like so:

$$DF = 1 + 0.03 = 1.03$$

Continuing on for NOx emissions,

$$EF_{aged} = 8.43 * 1.03 = 8.6829 \frac{g}{hp - hr}$$

$$Emissions = 1 * 107\ hp * 0.56 * 681 \frac{hrs}{yr} * 8.6829 \frac{g}{hp - hr} * 1 = 352,111 \frac{g}{yr}$$

Now we convert grams to tons

$$\frac{352,111\ g}{yr} * \frac{1\ lb}{453.592\ g} * \frac{1\ ton}{2000\ lb} = 0.388 \frac{ton\ NOx}{yr}$$

Now a diesel-powered example. What are the NOx emissions of a Tier 0, 120 hp diesel-powered AGSE engine with 13,415.7 cumulative hours and all EPA NONROAD2008a defaults for every other input?

Test Age Factor:

$$Age\ Factor = \frac{(13,415.7 * 0.59)}{4,667} = 1.70$$

Because the Age Factor is greater than 1, we determine the Deterioration Factor like so:

$$DF = 1 + 0.024 = 1.024$$

Continuing on for NOx emissions,

$$EF_{aged} = 8.38 * 1.024 = 8.58112 \frac{g}{hp - hr}$$

$$Emissions = 1 * 120\ hp * 0.59 * 732 \frac{hrs}{yr} * 8.58112 \frac{g}{hp - hr} * 0.95 = 422,486 \frac{g}{yr}$$

Now we convert grams to tons

$$\frac{422,486\ g}{yr} * \frac{1\ lb}{453.592\ g} * \frac{1\ ton}{2000\ lb} = 0.466 \frac{ton\ NOx}{yr}$$

For comparison, the DEQ estimated 0.482 tons of NOx emitted from the same diesel-powered engine inputs; remember though, that the DEQ sees regular updates and the methodology employed for gasoline-powered AGSE has not.

ATTACHMENT FOR 5.2.7.2

Describe how the Beneficiary will make documentation publicly available

Subparagraph 5.2.7.2 of the Environmental Mitigation Trust Agreement for State Beneficiaries requires that Beneficiaries include in their funding requests:

A commitment by the Beneficiary to maintain and make publicly available all documentation submitted in support of the funding request and all records supporting all expenditures of Eligible Mitigation Action funds, subject to applicable laws governing the publication of confidential business information and personally identifiable information, together with an explanation of the procedures by which the Beneficiary shall make such documentation publicly available;

The Nevada Division of Environmental Protection (NDEP), the Lead Agency for the State of Nevada, is committed to maintaining and making publicly available all documentation submitted support of the funding requests and all records supporting all expenditures of Eligible Mitigation Action funds, subject to applicable laws governing the publication of confidential business information and personally identifiable information.

The public will be able to view these records on the NDEP's website (<https://ndep.nv.gov>). The NDEP will maintain these records on a Volkswagen (VW) Environmental Mitigation Trust Fund specific webpage that will be designed to support public access and limit burden for the general public. The NDEP's VW specific webpage can currently be found at <https://ndep.nv.gov/air/vw-settlement>.

The NDEP has created an electronic listserv, open to the public, used to communicate news, events, and information related the Environmental Mitigation Trust Fund (Mitigation Fund). The listserv, NevadaVWFund, is advertised through the NDEP website and at public events related to the Mitigation Fund.

Furthermore, the Senate Committee on Finance and the Assembly Committee on Ways and Means of the Nevada Legislature has requested¹ “that the Division of Environmental Protection provide semiannual reports to the Interim Finance Committee regarding the status of the Volkswagen settlement and the Mitigation Fund, including recommendations by established working groups for the proposed activities to be supported by the settlement funds, and the process established to distribute settlement funds in accordance with the settlement terms.” The meetings of the Interim Finance Committee follow the Nevada Open Meeting Law (Nevada Revised Statues Chapter 241).

This commitment by the NDEP is subject to the following Nevada laws governing the publication of confidential business information and personally identifiable information.

Chapters 603A and 239B of the Nevada Revised Statutes (NRS) provide definitions and requirements for handling *personal information*.

¹ Letter from state Senator Joyce Woodhouse, Chair of the Senate Committee on Finance - September 29, 2017

NRS Section 603A.040 defines ‘Personal Information’ as:

1. *“Personal information” means a natural person’s first name or first initial and last name in combination with any one or more of the following data elements, when the name and data elements are not encrypted:*
 - (a) *Social security number.*
 - (b) *Driver’s license number, driver authorization card number or identification card number.*
 - (c) *Account number, credit card number or debit card number, in combination with any required security code, access code or password that would permit access to the person’s financial account.*
 - (d) *A medical identification number or a health insurance identification number.*
 - (e) *A user name, unique identifier or electronic mail address in combination with a password, access code or security question and answer that would permit access to an online account.*
2. *The term does not include the last four digits of a social security number, the last four digits of a driver’s license number, the last four digits of a driver authorization card number or the last four digits of an identification card number or publicly available information that is lawfully made available to the general public from federal, state or local governmental records.*

NRS Section 239B.030 – *Recorded, filed or otherwise submitted documents* - states that:

1. *Except as otherwise provided in subsections 2 and 6, a person shall not include and a governmental agency shall not require a person to include any personal information about a person on any document that is recorded, filed or otherwise submitted to the governmental agency on or after January 1, 2007.*
2. *If personal information about a person is required to be included in a document that is recorded, filed or otherwise submitted to a governmental agency on or after January 1, 2007, pursuant to a specific state or federal law, for the administration of a public program or for an application for a federal or state grant, a governmental agency shall ensure that the personal information is maintained in a confidential manner and may only disclose the personal information as required:*
 - (a) *To carry out a specific state or federal law; or*
 - (b) *For the administration of a public program or an application for a federal or state grant.*

➤ *Any action taken by a governmental agency pursuant to this subsection must not be construed as affecting the legality of the document.*
3. *A governmental agency shall take necessary measures to ensure that notice of the provisions of this section is provided to persons with whom it conducts business. Such notice may include, without limitation, posting notice in a conspicuous place in each of its offices.*
4. *A governmental agency may require a person who records, files or otherwise submits any document to the governmental agency to provide an affirmation that the document does not contain personal information about any person or, if the document contains any such personal information, identification of the specific law, public program or grant that requires the inclusion of the personal information. A governmental agency may refuse to record, file or otherwise accept a document which does not contain such an affirmation when required or any document*

which contains personal information about a person that is not required to be included in the document pursuant to a specific state or federal law, for the administration of a public program or for an application for a federal or state grant.

5. *Each governmental agency may ensure that any personal information contained in a document that has been recorded, filed or otherwise submitted to the governmental agency before January 1, 2007, which the governmental agency continues to hold is:*

(a) Maintained in a confidential manner if the personal information is required to be included in the document pursuant to a specific state or federal law, for the administration of a public program or for an application for a federal or state grant; or

(b) Obliterated or otherwise removed from the document, by any method, including, without limitation, through the use of computer software, if the personal information is not required to be included in the document pursuant to a specific state or federal law, for the administration of a public program or for an application for a federal or state grant.

↪ *Any action taken by a governmental agency pursuant to this subsection must not be construed as affecting the legality of the document.*

6. *A person may request that a governmental agency obliterate or otherwise remove from any document submitted by the person to the governmental agency before January 1, 2007, any personal information about the person contained in the document that is not required to be included in the document pursuant to a specific state or federal law, for the administration of a public program or for an application for a federal or state grant or, if the personal information is so required to be included in the document, the person may request that the governmental agency maintain the personal information in a confidential manner. If any documents that have been recorded, filed or otherwise submitted to a governmental agency:*

(a) Are maintained in an electronic format that allows the governmental agency to retrieve components of personal information through the use of computer software, a request pursuant to this subsection must identify the components of personal information to be retrieved. The provisions of this paragraph do not require a governmental agency to purchase computer software to perform the service requested pursuant to this subsection.

(b) Are not maintained in an electronic format or not maintained in an electronic format in the manner described in paragraph (a), a request pursuant to this subsection must describe the document with sufficient specificity to enable the governmental agency to identify the document.

↪ *The governmental agency shall not charge any fee to perform the service requested pursuant to this subsection.*

7. *As used in this section:*

(a) "Governmental agency" means an officer, board, commission, department, division, bureau, district or any other unit of government of the State or a local government.

(b) "Personal information" has the meaning ascribed to it in [NRS 603A.040](#).

Chapter 239 of the NRS provides general principles for the definition and the handling of public records. In particular, subsection 239.010.3 states that:

A governmental entity that has legal custody or control of a public book or record shall not deny a request made pursuant to subsection 1 to inspect or copy or receive a copy of a public book or record on the basis that the requested public book or record contains information that is

confidential if the governmental entity can redact, delete, conceal or separate the confidential information from the information included in the public book or record that is not otherwise confidential.

Chapter 445B of the NRS (Air Controls) specifically provides further directions on what is confidential information and how such information must be handle in the context of the Air Program of the NDEP. In particular section 445B.570 – *Confidentiality and use of information obtained by Department*²; penalty – states that (footnotes added for clarity):

1. *Any information which the Department obtains in the course of the performance of its duties pursuant to the provisions of this chapter is public information unless otherwise designated as confidential information pursuant to the provisions of this section.*
2. *The emission of an air contaminant which has an ambient air quality standard or emission standard or has been designated as a hazardous air pollutant by regulation of the Commission cannot be certified as being confidential.*
3. *Any confidential information received by the Commission³, the Director⁴ or any local control authority which is certified in writing to the recipient as confidential by the owner or operator disclosing the information and verified and approved in writing as confidential by the recipient must, unless the owner expressly agrees to its publication or availability to the public, be used only:
 - (a) *In the administration or formulation of air pollution controls;*
 - (b) *In compiling or publishing analyses or summaries relating to the condition of the outdoor atmosphere which do not identify any owner or operator or reveal any confidential information;*or
 - (c) *In complying with federal statutes, rules and regulations.**
4. *This section does not prohibit the use of confidential information in a prosecution for the violation of any statute, ordinance or regulation for the control of air pollution.*
5. *A person who discloses or knowingly uses confidential information in violation of this section is guilty of a misdemeanor, and is liable in tort for any damages which may result from such disclosure or use.*
6. *As used in this section, “confidential information” means information or records which:
 - (a) *Relate to dollar amounts of production or sales;*
 - (b) *Relate to processes or production unique to the owner or operator; or*
 - (c) *If disclosed, would tend to affect adversely the competitive position of the owner or operator.**

² Nevada Department of Conservation and Natural Resources (DCNR)

³ Nevada State Environmental Commission

⁴ Director of the Department of Conservation and Natural Resources

ATTACHMENT B

**ELIGIBLE MITIGATION ACTION MANAGEMENT PLAN INCLUDING DETAILED
BUDGET AND IMPLEMENTATION AND EXPENDITURES TIMELINE**

ATTACHMENT B

PROJECT MANAGEMENT PLAN PROJECT SCHEDULE AND MILESTONES

Milestone	Date
NDEP begins solicitation for projects through the competitive Diesel Emission Mitigation Fund	CY 2018, Q2
Project partner submits application to NDEP	CY 2018, Q3
NDEP selects project partner for funding and enters into Subgrant Agreement	CY 2018, Q4
Project partner enters into Contracts, Purchase Orders, etc.	CY 2018, Q4
NDEP Submits and Trustee acknowledges receipt of project certification and funding direction	CY 2019, Q1
NDEP submits second "Advancement" payment request to Trustee	CY 2019, Q2
NDEP submits third "Advancement" payment request to Trustee	CY 2019, Q3
NDEP submits fourth "Advancement" payment request to Trustee	CY 2019, Q4
NDEP submits fifth "Advancement" payment request to Trustee	CY 2020, Q1
NDEP submits sixth "Advancement" payment request to Trustee	CY 2020, Q2
Project partner begins receiving new equipment	CY 2020, Q2
Project Partner begins scrapping equipment as new equipment is received	CY 2020, Q2
NDEP submits seventh "Advancement" payment request to Trustee	CY 2020, Q3
NDEP submits eighth "Advancement" payment request to Trustee	CY 2020, Q4
Project partner provides final invoice for equipment replacement to NDEP	CY 2020, Q4
NDEP completes review and certifies payment direction to Trustee (Reimbursement)	CY 2020, Q3
Trustee acknowledges receipt of direction for payment (Reimbursement)	CY 2020, Q4
NDEP reports project completion	CY 2020, Q4

PROJECT BUDGET

Budget Category	Admin Expenses	Share of Replacement Budget Funded by the Trust	Cost Share (Paid by Project Partner)	Subtotal
Admin Expenditures ²				
Initial Payment Request	\$ 40,618.46			\$ 40,618.46
Second Payment Request	\$ 40,618.46			\$ 40,618.46
Third Payment Request	\$ 40,618.46			\$ 40,618.46
Fourth Payment Request	\$ 40,618.46			\$ 40,618.46
Fifth Payment Request	\$ 40,618.46			\$ 40,618.46
Sixth Payment Request	\$ 40,618.46			\$ 40,618.46
Seventh Payment Request	\$ 40,618.46			\$ 40,618.46
Eighth Payment Request	\$ 40,618.46			\$ 40,618.46
Final Payment Request	\$ 223,401.51			\$ 223,401.52
Admin Expenditure Subtotal	\$ 548,349.19			\$ 548,349.19
Equipment Expenditures ³				
1 All-Electric Baggage Tug		\$ 21,975.83	\$ 14,650.56	\$ 36,626.39
1 Baggage Tug Battery		\$ 6,452.78	\$ 4,301.86	\$ 10,754.64
Delivery Charge per each		\$ 833.84	\$ 555.89	\$ 1,389.73
1 All-Electric Belt Loader		\$ 34,493.40	\$ 22,995.60	\$57,489.00
1 Belt Loader Battery		\$ 4,345.16	\$ 2,896.77	\$ 7,243.93
Delivery Charge per each		\$ 1,520.41	\$ 1,013.61	\$ 2,534.02
Subtotal for 67 Baggage Tugs		\$ 1,960,584.15	\$ 1,307,056.77	\$ 3,267,640.92
Subtotal for 42 Belt Loaders		\$ 1,695,076.74	\$ 1,130,051.16	\$ 2,825,127.90
Project Totals⁴	\$ 548,349.19	\$ 3,655,661.29	\$ 2,437,107.53	\$ 6,641,118.01
Associated Percentages	15% of Total Trust Project Cost	60% of Replacement Cost	40% of Replacement Cost	

² The NDEP is planning to submit 8 “Advancement” payment requests to the Trustee to support the NDEP’s Administrative expenses associated with this project and one “Reimbursement” payment request to the Trustee that will include direction to provide funding to NDEP for Administrative expenses and Southwest Airlines for the replacement of the airport ground support equipment. The first “Advancement” request is included with this Beneficiary Eligible Mitigation Action Certification and the 7 that will follow are expected to be submitted at the beginning of the next calendar quarters—that is, April 1, 2018, July 1, 2018, etc.

³ Note that the NDEP is not covering the cost of the necessary charging infrastructure associated with the new All-Electric Airport Ground Support Equipment.

⁴ Note that Project Totals don’t perfectly align with Equipment Subtotals as they are based on 60 percent and 40 percent of the total project cost and some rounding errors will occur if calculated by looking at individual pieces of equipment.

PROJECTED TRUST ALLOCATIONS

ANNUAL PROJECTIONS	2019	2020
1. Anticipated annual project funding request to be paid through the Trust	\$ 203,092.30	\$ 4,000,918.18
2. Portion of anticipated project funding request to be paid through the Trust to cover Eligible Mitigation Action Administrative Expenditures	\$ 203,092.30	\$ 345,256.89
3. Portion of anticipated project funding request to be paid through the Trust to cover Eligible Mitigation Action Expenditures	\$ 0.00	\$ 3,655,661.29
4. Anticipated annual cost share	\$ 0.00	\$ 2,437,107.53
5. Anticipated total project funding by year (line 1 plus line 4)	\$ 203,092.30	\$ 6,438,025.71
CUMULATIVE PROJECTIONS		
6. Cumulative outstanding Trustee payments requested against cumulative approved Beneficiary allocation	\$ 765,107.29	
7. Cumulative Trustee payments made to date against cumulative approved Beneficiary allocation	\$ 529,311.84	
8. Beneficiary funding to be paid through the Trust for this project (sum of line 1)	\$ 4,204,010.48	
9. Total funding approved for Beneficiary Eligible Mitigation Actions, inclusive of current Action (sum of lines 6, 7, and 8)	\$ 5,498,429.61	
10. Beneficiary share of estimated funds remaining in Trust	\$ 24,344,712.64	
11. Estimated Beneficiary funds remaining in Trust after project completion (line 10 minus lines 6 and 8)	\$ 19,375,594.87	

ATTACHMENT C

**DETAILED PLAN FOR REPORTING ON ELIGIBLE MITIGATION ACTION
IMPLEMENTATION**

ATTACHMENT C

DETAILED PLAN FOR REPORTING ON ELIGIBLE MITIGATION ACTION IMPLEMENTATION

The Nevada Division of Environmental Protection (NDEP) will provide detailed reporting on this Volkswagen (VW) Environmental Mitigation Trust Fund for State Beneficiaries Eligible Mitigation Action project in three ways: 1, timely updates to NDEP's VW Environmental Mitigation Trust Fund webpage; 2, semiannual reporting to the Nevada Legislature's Interim Finance Committee (IFC); and 3, Nevada's semiannual reporting obligation to Wilmington Trust (the "Trustee").

NDEP maintains a VW Environmental Mitigation Trust Fund specific webpage that has been designed to support public access and limit burden for the general public. The NDEP's VW specific webpage can currently be found at <https://ndep.nv.gov/air/vw-settlement>. Timely updates to the webpage will inform the general public on the project's status as well as when this Eligible Mitigation Action has been completed.

The Senate Committee on Finance and the Assembly Committee on Ways and Means of the Nevada Legislature have requested "that the Division of Environmental Protection provides semiannual reports to the IFC regarding the status of the Volkswagen settlement and the Mitigation Fund, including recommendations by established working groups for the proposed activities to be supported by the settlement funds, and the process established to distribute settlement funds in accordance with the settlement terms." The meetings of the IFC follow the Nevada Open Meeting Law (Nevada Revised Statutes Chapter 241). In the reports submitted to the IFC details describing the progress of implementing this Eligible Mitigation Action will be provided. In the report submitted immediately following the completion of the project, details describing the completion of the project will also be provided.

Subparagraph 5.3 of the Environmental Mitigation Trust Agreement for State Beneficiaries details Nevada's Reporting Obligations:

"For each Eligible Mitigation Action, no later than six months after receiving its first disbursement of Trust Assets, and thereafter no later than January 30 (for the preceding six-month period of July 1 to December 31) and July 30 (for the preceding six-month period of January 1 to June 30) of each year, each Beneficiary shall submit to the Trustee a semiannual report describing the progress implementing each Eligible Mitigation Action during the six-month period leading up to the reporting date (including a summary of all costs expended on the Eligible Mitigation Action through the reporting date). Such reports shall include a complete description of the status (including actual or projected termination date), development, implementation, and any modification of each approved Eligible Mitigation Action. Beneficiaries may group multiple Eligible Mitigation Actions and multiple sub-beneficiaries into a single report. These reports shall be signed by an official with the authority to submit the report for the Beneficiary and must contain an attestation that the information is true and correct and that the submission is made under penalty of perjury. To the extent a Beneficiary avails itself of the DERA Option described in Appendix D-2, that Beneficiary may submit its DERA Quarterly Programmatic Reports in satisfaction of its obligations under this Paragraph as to those Eligible Mitigation Actions funded through the DERA Option. The Trustee shall post each semiannual report on the State Trust's public-facing website upon receipt."

Finally, the NDEP shall, in the next semiannual report following the Trustee's approval of this project, describe the progress implementing this Eligible Mitigation Action that will include a summary of all costs expended on the Eligible Mitigation Action through the reporting date. The report will also include a complete description of the status, development, implementation (including project schedule and milestone updates), and any modification to this Eligible Mitigation Action.

ATTACHMENT D

**DETAILED COST ESTIMATES FROM SELECTED OR POTENTIAL VENDORS FOR
EACH PROPOSED EXPENDITURE EXCEEDING \$25,000**



T137-V3

AC Electric Tow Tractor



The Charlatte Model T137-V3 Tow Tractor is our newest design of our best selling T137 line of tractors. It is a self propelled battery powered electric support vehicle designed to tow a variety of material handling carts and dollies. Power for the main drive is supplied by a 40 hp (30 kw) high efficiency/low maintenance AC motor which is coupled directly to the rear axle. The unit has excellent visibility and has a maximum speed of 18 mph (29 km/h) when empty. Drawbar capacity is 4000 lb (1814 kg).

Options include: Complete cab assembly with heater/defroster, mirrors, wiper, and vinyl doors, and power assisted master cylinder.

STANDARD FEATURES

- Trusted Design With Improvements
- New All-Steel Dash For More Durable Operator Environment
- More Powerful Hydraulic Braking
- New Front Axle Design Improves Ground Clearance / Features Larger Brake Calipers
- Power Steering by Hydraulic Accumulator Provides Quiet Operation
- Highly Maneuverable – 117" Turning Radius
- Inching Device

T137-V3

TECHNICAL CHARACTERISTICS

Manufacturer	Manufacturer		Charlotte of America
Model	Manufacturer's Designation		T137-V3
Energy Source	Battery	Volts	80
Battery Capacity	Ampere Hour Range	AH	500 – 625
Battery Weight	Maximum	lb / kg	3327 / 1512
	Minimum	lb / kg	2556 / 1162
Controller	Manufacturer		Curtis
	Model		1238
80 Volt AC MOSFET controller with CAN buss and serial communication			
Motor	Manufacturer		ABM
	Rating @ 80 Volts	hp / kw	40.0 / 30.0
	Rating Speed	rpm	1400
Dimensions	Length w/Hitch Extension (A)	in / mm	124.6 / 3164
	Length w/o Hitch Extension	in / mm	121.7 / 3090
	Width (B)	in / mm	52.0 / 1320
	Height with Cab (C)	in / mm	69.5 / 1765
	Height w/o Cab (D)	in / mm	48.4 / 1230
	Sitting Height	in / mm	30.3 / 770
	Outside Turning Radius	in / mm	117.1 / 2975
Performance	Speed Empty	mph / km/h	18.0 / 29.0
	Rated Tractive Effort w/3320# Battery	lb / kg	4000 / 1814
	Wt. Front/Rear w/3320# Battery	lb / kg	2877/1308-3973/1808
Chassis	Frame Mfg. W/ Jigs & Fixtures		Yes
	Auto Design Wiring Harness		Yes
	Wheels Front/Rear		Heavy Duty Split Ring
	Tires Front		6.00R X 9
	Tires Rear		7.00R X 12
	Wheel Base C/L (E)	in / mm	58.7 / 1490
	Track Width C/L Front/Rear	in / mm	43.3/1100-42.1/1070
	Ground Clearance	in / mm	5.9 / 150
	Service Brakes	Front	Disc
		Rear	Disc (Standard) Drum (Optional)
	Parking Brake		Rear Axle Brakes
	Suspension	Front	Leaf Springs / Shock Absorbers
		Rear	Leaf Springs
Drive Axle	Motor Direct Coupled To Axle		Yes
	Reduction In Differential		Yes
	Reduction		17.45:1

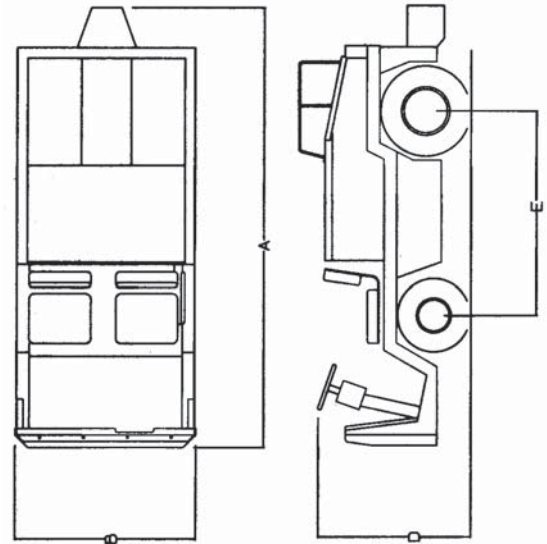

Charlotte America

P.O. Box 968
600 Mountain Lane
Bluefield, VA 24605
Phone: (276) 326-1510
Fax: (276) 326-1602
e-mail: equipmentsales@charlatteus.com

Charlotte France

Z.I. – Route du Boutoir
89210 Brienon sur Armancon (France)
Phone: (33) 386 43 01 30
Fax: (33) 386 43 04 66
e-mail: contact@charlattemanutention.fayat.com

Charlotte United Kingdom

LSUK Building
Spindle Way
RH10 1TG Crawley West Sussex
United Kingdom
Phone: (44) 01 293 529 640
e-mail: ukparts@charlattemanutention.fayat.com

These descriptions are given as an indication only and do not represent a commitment



ALTUS

The World's only Cloud-Connected Charger for Demanding eGSE Applications

Take Control of Your eGSE Fleet

Minit Charger, a recognized leader in fast charging technology, just raised the bar again. Altus, our robust charging solution for eGSE is now connected to our cloud portal AssetPro. Altus empowers airport personnel to better manage their fleet with unprecedented visibility and insight on charger and GSE performance.

- + Dual Port Charger
- + Multiple Power Output Options
- + High-Frequency IGBT Technology
- + Outdoor Rated Enclosure
- + Monitor/Configure Charger from Anywhere
- + Charger Can Share Jet Bridge Power with Optional Bridge Power Manager
- + Wireless Battery Module
- + Break-Away Charge Cables
- + High-Visibility Status LEDs
- + Four-line Status Display

Advanced Battery Management

In addition to our patented technology, we have added advanced battery management to improve battery performance and extend life. Altus can be purchased with an optional wireless battery management system which sends up-to-the-minute data on battery voltage, amp hours delivered and returned, temperature and electrolyte level to the AssetPro server.



AssetPro Cloud-Based Asset Management

AssetPro collects data from all chargers, battery management devices, and even vehicle monitoring devices. The data is organized in heads-up dashboards, detailed status pages, and customizable reports for intelligent management of the entire fleet.

AssetPro can also send emails to management when equipment needs immediate attention.

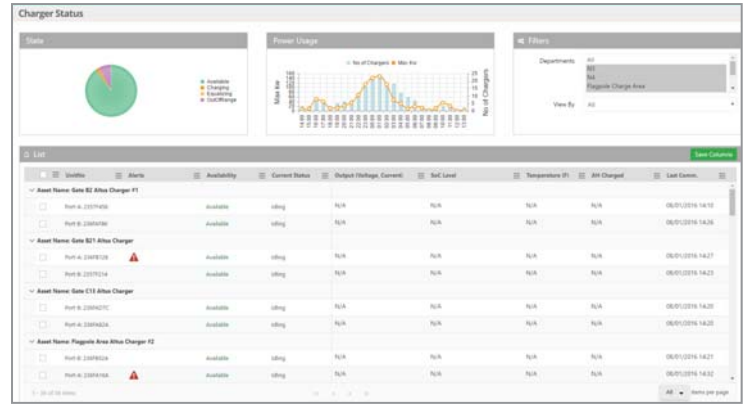

Altus Charger Specifications

Input Power	Output Power/Port	General
Altus 22kW Dual Port Charger		
380/400/480 VAC, 3 Phase, 50/60 Hz	Voltage: 24V-96V nominal	Dimension: 68" H x 32" W x 24" D
Rated Current @ 480VAC: 32 A	Max Current: 130 A	Weight: (Approx) 350 Lbs. / 160kg
Rated Current @ 400VAC: 40 A		
Rated Current @ 380VAC: 42 A		
Efficiency: up to 93%		
Altus 30kW Dual Port Charger		
480 VAC, 3 Phase, 50/60 Hz	Voltage: 24V-96V nominal	Dimension: 68" H x 32" W x 24" D
Rated Current @ 480VAC: 42 A	Max Current: 320 A	Weight: (Approx) 450 Lbs. / 205kg
Altus 40kW Dual Port Charger		
480 VAC, 3 Phase, 50/60 Hz	Voltage: 24V-96V nominal	Dimension: 68" H x 32" W x 24" D
Rated Current @ 480VAC: 54 A	Max Current: 320 A	Weight: (Approx) 450 Lbs. / 205kg

Enclosure: NEMA 3R / IP23 Outdoor rated

Warranty: 2 Years Parts, 1 Year Labor

Temperature: -13° to 104° F (-25° to 40° C)

Certifications: UL1564 for Outdoor Use

As part of our continuous improvement policy, product specifications may change without notice.

MINIT CHARGER
www.minitcharger.com

908-789-8700



NexSys[®]
POWER WHEN YOU NEED IT

NexSys[®] batteries—powering even more applications



Classified by UL to ANSI/UL 583,
“Electric-Battery-Powered Industrial Trucks”

Breakthrough performance from NexSys® batteries

More power for higher capacity lift trucks

For nearly a decade, our Thin Plate Pure Lead (TPPL) NexSys® batteries have been providing cost-effective power for small traction applications. Today, our expanded line of NexSys batteries puts that same trusted TPPL technology to work for a wide range of higher capacity lift truck vehicles.

Faster, more flexible charging

The expanded NexSys battery line includes configurations that can fast-charge in just under an hour. NexSys batteries give operators the ability to charge during breaks, at the end of a shift or anytime a vehicle is stopped. NexSys batteries can even be put back into service before they are fully charged.

Outworks and outlasts conventional batteries

The expanded NexSys battery line includes configurations that can fast charge in just under an hour and be opportunity charged to work for up to 16 hours. For operators, virtually maintenance-free NexSys batteries involve little work at all – no watering, changing or spills.

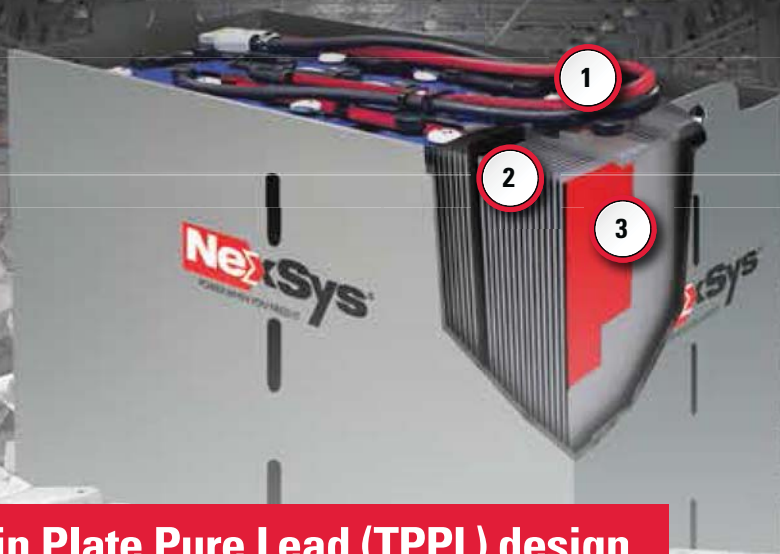

Thin Plate Pure Lead (TPPL) design



Robust intracell connections

Cell connectors are casted and bonded to the plates to resist vibration.



99% pure lead plates

Extremely thin, pure lead plates mean more of them fit into the battery. More plates mean more power.



Compressed AGM plate separators

Absorbed Glass Mat (AGM) design prevents spills and delivers extreme vibration resistance.



Lower your Total Cost of Ownership (TCO)

NexSys® batteries provide cost-effective motive power for even the highest capacity lift trucks. Minimal-gassing and a no-watering design make NexSys batteries ideal for use in sensitive production areas, retail environments or other public spaces.



Power for Class I, II and III applications

- Counterbalance trucks
- Reach trucks
- Pallet trucks
- Order pickers
- Automated Guided Vehicles (AGVs) and Laser Guided Vehicles (LGVs)

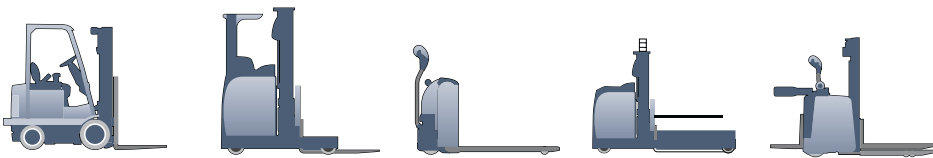

NexSys® battery chargers

Designed for use with NexSys batteries, NexSys battery chargers slash recharge times while optimizing battery cycle life and fleet efficiency.



Features and benefits

- No watering, changing or equalization
- Fast charging from 40-80% State of Charge (SOC) in less than one hour
- Opportunity charging in less than four hours with appropriately-sized NexSys battery charger
- Extreme shock and vibration resistance
- Energy throughput up to 160% per 24 hours*
- Suitable for 10- to 16-hour workdays
- Excellent cycle life - up to 1540 cycles at 60% Depth of Discharge (DOD)
- Minimal gassing

* Maximum Depth of Discharge (DOD) must be observed.



ENERSYS WORLD HEADQUARTERS

2366 Bernville Road
Reading, PA 19605
+1-800-EnerSys
Fax: +1-610-372-8613

ENERSYS CANADA INC.

61 Parr Boulevard Unit 3
Bolton, Ontario • Canada L7E 4E3
+1-800-363-4877
Fax: +1-905-951-4441

ENERSYS DE MEXICO

Ave Lopez Mateos #4210
Colonia Casa Blanca • C.P. 66475
San Nicolas de los Garza, N.L. Mexico
+52-818-329-6400
Fax: +52-818-329-6489

www.enersys.com



Quotation

Quote Number
SWA01/06/25/18

600 MOUNTAIN LANE • P. O. BOX 968 • BLUEFIELD, VA 24605
 TELEPHONE (276) 326-1510 • FAX (276) 326-1602
 E-MAIL: CHARLATTEUS@CHARLATTEUS.COM

Quote Date:
6-25-18

Page:
1

Quoted to: Southwest Airlines (LAS)

Customer ID	Good Through	Payment Terms	Sales Rep
SWA	60 Days	30 Days Net FOB Bluefield, VA.	RL
Quantity	Description	Unit Price	Extension
One (1) Each	Charlatte Electric Model T137-V3 AC Tow Tractors Complete with the following features: <ul style="list-style-type: none"> • 40 HP 80V AC Motor directly coupled to Charlatte drive axle • 80V Curtis AC Controller • "E" Type Hitch (With "1" inch Pin) • Power Steering with Accumulator Setup • DC/DC Converter provides 400 watts of 12V power <u>Southwest Standard Contractual Setup</u> <ul style="list-style-type: none"> • Maintenance Friendly All-Steel Dash Console • New Front Axle Design – Better Ground Clearance – Larger Brake Calipers • More Powerful Hydraulic Braking • Rear Disc Brakes • 80V DC Battery Supplied By Southwest Airlines • 4,000 lb. drawbar pull • LED Style Tail, Turn and Marker Lights (Mounted on Rear Cover) • When Pictograms Are Used A Legend Must Accompany Them In Full View Of The Operator • E-Hitch On Rear Painted Yellow • Etec 9 Pin Charging Connection For Fast Charging • Continental RV20 Front & Rear Tires • SWA Specified Blue Paint • One CD (PDF) Electronic Manual Must Accompany Each Unit Delivered • Electronic Accelerator Pedal • Keyless Power ON/OFF Switch • Regen Braking • Service Brakes Dual Split System Front Disc / Rear Disc • Parking Brake, with adjustable Orschlin Handle (Rear Disc) • Front Rubber Bumper (1inch) • Rear Hitch Extension • Hip Restraint (Passenger Side) • Seat Switch (Lock out) • Traction Tread - Fibergrate Floor Plate • SWA Spec 6 LED Headlights • Remove Inching Controls/Rear Deck Railing • Round Reflectors – 4 Corners • Accelerator Pedal Wiring Cover (No Cab Installation) • Curtis – AC Steering Pump Motor System • Pedal Guard • SWA Specified Ultrabrand Seats – Part Number 1110-0107 • SWA Specified Seat Belts – Part Number 80537929-00-AB – Yellow Seat Belt • Installation of Acuity Battery System • Installation of SWA Specified Decals/Asset Plates Per SWA SLING Manual 	\$ 33,835.00	\$ 33,835.00
UNLESS OTHERWISE QUOTED PRICE IS F.O.B. CHARLATTE PLANT, BLUEFIELD, VA.		Subtotal Sales Tax (8.25%) Total	\$ 33,835.00 \$ 2,791.39 \$ 36,626.39



ALLEN ENERGY

TO: ERIC KENNEY
SOUTHWEST AIRLINES

8815 CONROY-WINDERMERE RD., #223
ORLANDO, FL 32835
PH: 407-240-0909
FX: 407-386-6506

DATE: 6/26/2018

REF: LAS

tammyumstead@allenenergy.com

Qty	CATALOG #	DESCRIPTION	UNIT PRICE	*EXT. PRICE W/SALES TAX (8.25%)
1	506428D-WAAY	<p>CHARLATTE T137 BAG TRACTOR DESERTHOG 40-E125D-9 (80V - 500AH) BATTERY WITH A 40 CELL FLOW-RITE SPW SYSTEM INSTALLED</p> <p><i>*NOTE: SALES TAX IS REFERENCED FOR "TOTAL" COST ONLY. ALLEN ENERGY DOES NOT COLLECT & REMIT SALES TAX AS SOUTHWEST PAYS THE SALES TAX DIRECT TO THE APPLICABLE STATE.</i></p> <p>LEAD TIME: 7-8 WEEKS AFTER RECEIPT OF ORDER TERMS: NET 30 DAYS PO'S: ISSUE TO ALLEN ENERGY FOB: RICHMOND, KY - FREIGHT ALLOWED TO CHARLATTE OF AMERICA PRICING VALID THRU 12/31/2018</p> <p>If you have any questions, please feel free to contact me. Thank you. Tammy Umstead</p>	\$ 9,935.00	\$ 10,754.64





**Southern Pride
Trucking Inc. ®**

**QUOTE #
12527**

QUOTE FOR: ...ERIC KENNEY SOUTHWEST AIRLINES 7510 AVIATION PLACE SUITE 130 DALLAS, TX 75235	WNGSEBILL
BILL TO: SOUTHWEST AIRLINES ATTN: POSITION ID 42058855 7510 AVIATION PLACE SUITE 130 DALLAS, TX 75235	WNGSEBILL

Date 6/25/2018
Expired on 12/22/2018
Pickup by 6/25/2018
Deliver by 6/25/2018

FROM	TO
CHARLATTE AMERICA 600 MOUNTAIN LANE BLUEFIELD, VA 24605	SOUTHWEST AIRLINES 727 WRIGHT BROTHERS LANE LAS VEGAS, NV 89119

CHARLBLF

WNGSELAS

	COMMODITY DESCRIPTION	WEIGHT	RATE	CHARGE
4	CHARLATTE T137 TOW TRACTOR	32000	2.150	4,650.45
	FUEL SURCHARGE		0.420	908.46

DIMENSIONS: L44' W5' H5'

HM

Quote question please call:
(800) 922-8600

ESTIMATE:	\$	5,558.91
------------------	-----------	-----------------

Southwest Airlines 2018 Pricing

Beltloader - Electric 660E

Unit Price	\$53,108
Sales Tax (8.25%)	\$4,381
Total Cost	\$57,489



BAT-233A	Southwest supplied battery _____
BEL-034	RF belt Control Push/twist E-Stop
BEL-035	RR Belt Control & Push/Twist E-Stop
BEL-049	Change LF Belt Control to Hall Belt Control
BEL-050	Change LR Belt Control To Hall Belt Control
BEL-051	Change RF Belt Control TO Hall Belt Control
BEL-052	Change RR Belt Control To Hall Belt Control
BUM-010	Front Rubber Bumper Full Width
BUM-041	Bumper "D" Style on front of Std Convy
BUM-068	Driver Compartment Bumpers W/O Cab
CHO-019	Chock Box 16 x 16 x 6
CHO-021	Wheel Chocks with a 48" 1/4" Chain Connecting the Chocks
DEC-085	Install Customer Supplied Decals
DEC-086	Stamp Number in Frame
DOC-007	SWA IBIS Documentation
ELE-068	9 Pin Posi Charge
FLO-019	Traction Tread
GUA-008	Conveyer Hoop Guard
GUA-120	Conveyer Bottom Closeout Front Only
	LED Headlights Standard
	LED Tail Lights & Backup Lights standard
LIG-096A	Headlights Wired Thru Ignition
LIG-176	Single LED Worklight on Solid Post
RUB-003	Rub Rails, 5 Plaes
SEA-079	Ultraseat Bucket Seat
SEA-108	Yellow Retract, Flip Open Latch Seat Belts

Options that we are currently working with Engineering & Purchasing

Self Centering roller (supplier Luis Criswell)
Central Lubrication System



ALLEN ENERGY

TO: ERIC KENNEY
SOUTHWEST AIRLINES

8815 CONROY-WINDERMERE RD., #223
ORLANDO, FL 32835
PH: 407-240-0909
FX: 407-386-6506

DATE: 6/26/2018

REF: LAS

tammyumstead@allenenergy.com

Qty	CATALOG #	DESCRIPTION	UNIT PRICE	*EXT. PRICE W/SALES TAX (8.25%)
1	505189-WGRN	<p>TUG 660E-AC BELT LOADER WORKHOG 40-E75-9 (80V - 300AH) BATTERY WITH A 40 CELL FLOW-RITE SPW SYSTEM INSTALLED</p> <p><i>*NOTE: SALES TAX IS REFERENCED FOR "TOTAL" COST ONLY. ALLEN ENERGY DOES NOT COLLECT & REMIT SALES TAX AS SOUTHWEST PAYS THE SALES TAX DIRECT TO THE APPLICABLE STATE.</i></p> <p>LEAD TIME: 7-8 WEEKS AFTER RECEIPT OF ORDER TERMS: NET 30 DAYS PO'S: ISSUE TO ALLEN ENERGY FOB: RICHMOND, KY - FREIGHT ALLOWED TO TUG TECHNOLOGIES PRICING VALID THRU 12/31/2018</p> <p>If you have any questions, please feel free to contact me. Thank you. Tammy Umstead</p>	\$ 6,690.00	\$ 7,241.93





**Southern Pride
Trucking Inc. ®**

**QUOTE #
12528**

QUOTE FOR:	WNGSEBILL
...ERIC KENNEY SOUTHWEST AIRLINES 7510 AVIATION PLACE SUITE 130 DALLAS, TX 75235	
BILL TO:	WNGSEBILL
SOUTHWEST AIRLINES ATTN: POSITION ID 42058855 7510 AVIATION PLACE SUITE 130 DALLAS, TX 75235	

Date 6/25/2018
 Expired on 12/22/2018
 Pickup by 6/25/2018
 Deliver by 6/25/2018

FROM	TO
------	----

TUGATL

WNGSELAS

TUG TECHNOLOGIES
 2652 S MAIN ST NW
 KENNESAW, GA 30144

SOUTHWEST AIRLINES
 727 WRIGHT BROTHERS LANE
 LAS VEGAS, NV 89119

	COMMODITY DESCRIPTION	WEIGHT	RATE	CHARGE
2	TUG 660E BELTLOADER	18000	2.150	4,239.80
	FUEL SURCHARGE		0.420	828.24

DIMENSIONS: L48' W6'06" H5'

HM

Quote question please call:
 (800) 922-8600

ESTIMATE:	\$	5,068.04
------------------	-----------	-----------------