

APPENDIX D-4
Beneficiary Eligible Mitigation Action Certification

BENEFICIARY ELIGIBLE MITIGATION ACTION CERTIFICATION

Beneficiary Nez Perce Tribe

Lead Agency Authorized to Act on Behalf of the Beneficiary Nez Perce Tribe Air Quality Program
(Any authorized person with delegation of such authority to direct the Trustee delivered to the Trustee pursuant to a Delegation of Authority and Certificate of Incumbency)

Action Title:	Nez Perce Tribe Truck Replacement and Electric Vehicle Charging Station
Beneficiary's Project ID:	NPT-2019-VW-01
Funding Request No.	<i>(sequential)</i> 1
Request Type: (select one or more)	<input type="checkbox"/> Reimbursement <input checked="" type="checkbox"/> Advance <input type="checkbox"/> Other (specify): _____
Payment to be made to: (select one or more)	<input checked="" type="checkbox"/> Beneficiary <input type="checkbox"/> Other (specify): _____
Funding Request & Direction (Attachment A)	<input checked="" type="checkbox"/> Attached to this Certification <input type="checkbox"/> To be Provided Separately

SUMMARY

Eligible Mitigation Action	<input checked="" type="checkbox"/> Appendix D-2 item (specify): <u>EMAs 1, 6, 9</u>
Action Type	<input type="checkbox"/> Item 10 - DERA Option (5.2.12) (specify and attach DERA Proposal): _____
Detailed Description of Mitigation Action Item Including Community and Air Quality Benefits (5.2.2): See Addendum	
Estimate of Anticipated NO_x Reductions (5.2.3): See Addendum	
Identification of Governmental Entity Responsible for Reviewing and Auditing Expenditures of Eligible Mitigation Action Funds to Ensure Compliance with Applicable Law (5.2.7.1): See Addendum	
Describe how the Beneficiary will make documentation publicly available (5.2.7.2). See Addendum	
Describe any cost share requirement to be placed on each NO_x source proposed to be mitigated (5.2.8). See Addendum	
Describe how the Beneficiary complied with subparagraph 4.2.8, related to notice to U.S. Government Agencies (5.2.9). See Addendum	

If applicable, describe how the mitigation action will mitigate the impacts of NOx emissions on communities that have historically borne a disproportionate share of the adverse impacts of such emissions (5.2.10).
See Addendum

ATTACHMENTS
(CHECK BOX IF ATTACHED)

- | | | |
|-------------------------------------|---------------------|---|
| <input checked="" type="checkbox"/> | Attachment A | Funding Request and Direction. |
| <input checked="" type="checkbox"/> | Attachment B | Eligible Mitigation Action Management Plan Including Detailed Budget and Implementation and Expenditures Timeline (5.2.4). |
| <input checked="" type="checkbox"/> | Attachment C | Detailed Plan for Reporting on Eligible Mitigation Action Implementation (5.2.11). |
| <input checked="" type="checkbox"/> | Attachment D | Detailed cost estimates from selected or potential vendors for each proposed expenditure exceeding \$25,000 (5.2.6). [Attach only if project involves vendor expenditures exceeding \$25,000.] |
| <input type="checkbox"/> | Attachment E | DERA Option (5.2.12). [Attach only if using DERA option.] |
| <input type="checkbox"/> | Attachment F | Attachment specifying amount of requested funding to be debited against each beneficiary's allocation (5.2.13). [Attach only if this is a joint application involving multiple beneficiaries.] |

CERTIFICATIONS

By submitting this application, the Lead Agency makes the following certifications:

1. This application is submitted on behalf of Beneficiary The Nez Perce Tribe, and the person executing this certification has authority to make this certification on behalf of the Lead Agency and Beneficiary, pursuant to the Certification for Beneficiary Status filed with the Court.
2. Beneficiary requests and directs that the Trustee make the payments described in this application and Attachment A to this Form.
3. This application contains all information and certifications required by Paragraph 5.2 of the Trust Agreement, and the Trustee may rely on this application, Attachment A, and related certifications in making disbursements of trust funds for the aforementioned Project ID.
4. Any vendors were or will be selected in accordance with a jurisdiction's public contracting law as applicable. (5.2.5)
5. Beneficiary will maintain and make publicly available all documentation submitted in

support of this funding request and all records supporting all expenditures of eligible mitigation action funds subject to applicable laws governing the publication of confidential business information and personally identifiable information. (5.2.7.2)

DATED: 8 August 2019

Julie D. Simpson, Coordinator

[NAME]

[TITLE]

SIGNATURE: 

Nez Perce Tribe Air Quality Program

[LEAD AGENCY]

for

The Nez Perce Tribe

[BENEFICIARY]



Nez Perce Tribe VW Settlement

Addendum to D-4 Beneficiary Eligible Mitigation Action Certification

August 2019

5.2.2

During the second funding cycle of the Volkswagen Settlement Environmental Mitigation Trust for Indian Tribes, the Nez Perce Tribe will replace two government-owned vehicles:

- One (1) government-owned 2003 Kenworth T8 Series Truck, eligible per Class 8
- One (1) government-owned 1999 Ford F-450 Truck, eligible per Class 4

The Tribe will also establish one Light Duty Zero Emission Vehicle Supply Equipment via one (1) multi-port electric vehicle fast charging station at the Nez Perce Tribe Itseyeye Casino, located in the City of Kamiah on the Nez Perce Reservation.

The eligible vehicles to be replaced are the following:

Year	Make	Model	Description	VIN
2003	Kenworth	T8 Series Large Freight Truck	Used by Nez Perce Tribe Fisheries Department <i>Class 8 Eligible</i>	IXKDDB9X93R395284
1999	Ford	F-450 Medium Freight Truck	Used by Nez Perce Tribe Forestry and Fire Management Division <i>Class 4 Eligible</i>	1FDXW47F3XEB48473

The eligible vehicles will be scrapped and replaced with low-emission new diesel truck. The Nez Perce Tribe understands the term "scrapped" means to render inoperable and available for recycle, and, at minimum, to specifically cut a 3" or larger hole in the engine block of each vehicles and, for vehicles to be replaced as part of this project, to disable the chassis by cutting the vehicles' frame rails completely in half.

The Nez Perce Tribe will acquire the following low-emission replacement vehicles:

Year	Make	Model	Description	Qty	Cost
2020	Kenworth	T-800	Heavy Freight Truck	1	\$117,106
2020	Ford	F-450	Medium Freight Truck w/ be	1	\$67,715
				Total	\$184,821

The total cost of the replacement vehicles will be \$184,821. Costs have been obtained from qualified dealers and reflect delivery to Lapwai, Idaho, on the Nez Perce Reservation. The Kenworth T-800 Truck amount of \$117,106 represents a reduced governmental rate package.

Specifications for the Light Duty Zero Emission Vehicle Supply Equipment:

Electric Vehicle Charging Equipment Project Component	Description	Tribe Cost-Share	Mitigation Funds	Total Cost
One (1) Charge Point Zero Emission Electric Vehicle Fast Charging Station	62.5 kW Multi-port DC FC Electric Vehicle Charging Station with CHAdeMO & SAE Combo standards	\$7035	\$35,574	\$42,609
Charging Station Shelter	Local Estimate	\$1400	0	\$1400
Charging Station Electricity Development	Local Estimate	\$20,000	0	
Total		\$28,435	\$35,574	\$64,009

The total cost of the light duty zero emission electric vehicle charging station will be \$64,009. The charging station will be located at the Nez Perce Tribe Itseyeye Casino complex adjacent to Highway 12 in Kamiah. The casino property is well-lit, has sufficient electrical capacity for the charging station, and maintains 24/7 desk service and 24/7 security inside and throughout the complex.

The electric vehicle charging station is as part of a corridor project in Idaho and other states to "electrify the West" with zero emission charging stations available to the public to power their electric vehicles. The project complements an initial electric vehicle charging station authorized in 2019 by the Nez Perce Tribe with placement on the reservation near Lapwai, 60 miles west of Kamiah.

The community and air quality benefits from the mitigation project will include energy efficiency and a reduction in pollution, including reduced emissions of NOx, reduced emission of noise, reduced fuel consumption, and reduced fuel costs.

5.2.3

The Eligible Mitigation Actions to be undertaken by the Nez Perce Tribe will result in a significant reduction in NOx emissions, other pollutants, and fuel consumption. Detailed data regarding Diesel Emissions Qualified (DEQ) standards of the U.S. Environmental Protection Agency and the Eligible Mitigation Action undertaken for vehicle replacement are as follows:

Vehicle	Annual Reduction in NOx Emissions	Lifetime Reduction in NOx Emissions	Annual Reduction in PM2.5	Lifetime Reduction in PM2.5
Ford F-450 Truck	91.5%	91.5%	98.3%	98.3%

Kenworth T8 Truck	88.6%	91.5%	97.4%	97.4%
-------------------	-------	-------	-------	-------

5.2.7.1

The governmental entities responsible for review and audit expenditures of eligible Mitigation Action Funds to ensure compliance with applicable law are the Office of Legal Counsel and the Finance Office of the Nez Perce Tribe.

5.2.7.2

The Nez Perce Tribe is committed to maintaining and making publicly available all documentation submitted in support of the Funding Request and all records supporting all expenditures of Eligible Mitigation Action funds, subject to applicable laws governing the publication of confidential business information and personally identifiable information.

As stated in D-3, the Nez Perce Tribe will establish a webpage dedicated to the funding received from the VW Settlement Trust, which will include a link for members of the public to request additional information and documents related to the funding request and expenditures of funds. The Nez Perce Tribe will endeavor to respond to such requests within ten (10) business days and, when documents are requested, will advise the individual within that timeframe of the procedure for reviewing such documents.

5.2.8

This project involves a limited cost share. The total cost of the project is \$265,595. It has been determined that the Nez Perce Tribe is eligible for \$237,160 from the Environmental Mitigation Trust in the second funding cycle. The Tribe will commit \$28,435 to the project.

5.2.9

No government agency has contacted the Nez Perce Tribe regarding the Tribe's intent as a Beneficiary.

5.2.10

Not Applicable

Emissions Results for Nez Perce Tribe Environmental Mitigation Action

The combined results for all groups and upgrades in the project are from the U.S. Environment Protection Agency Diesel Emissions Quantifier.¹

These results include the identified eligible Vehicles to be replaced in this Environmental Mitigation action.

¹ Emissions from the electrical grid are not included in the results.

Emission Results and Health Benefits for Project: NezPerce 99-19 F450

Emission Results

Health Benefits

Emission Results ?

Here are the combined results for all groups and upgrades entered for your project.¹

Annual Results (short tons)²	NO_x	PM2.5	HC	CO	CO₂	Fuel³
Baseline for Upgraded Vehicles/Engines	0.121	0.009	0.026	0.068	16.5	1,463
Amount Reduced After Upgrades	0.111	0.009	0.025	0.063	0.0	0
Percent Reduced After Upgrades	91.5%	98.3%	95.4%	93.1%	0.0%	0.0%

Lifetime Results (short tons)²	NO_x	PM2.5	HC	CO	CO₂	Fuel³
Baseline for Upgraded Vehicles/Engines	0.121	0.009	0.026	0.068	16.5	1,463
Amount Reduced After Upgrades	0.111	0.009	0.025	0.063	0.0	0
Percent Reduced After Upgrades	91.5%	98.3%	95.4%	93.1%	0.0%	0.0%

Lifetime Cost Effectiveness (\$/short ton reduced)						
Capital Cost Effectiveness ⁴ (unit & labor costs only)	\$537,812	\$6,890,461	\$2,369,235	\$945,726	\$0	
Total Cost Effectiveness ⁴ (includes all project costs)	\$537,812	\$6,890,461	\$2,369,235	\$945,726	\$0	

¹ Emissions from the electrical grid are not included in the results.

² 1 short ton = 2000 lbs.

³ In gallons; fuels other than ULSD have been converted to ULSD-equivalent gallons.

⁴ Cost effectiveness estimates include only the costs which you have entered.

Remaining Life	1999 Ford F-450: Short Haul - Single Unit Class 4-5	1 years
-----------------------	--	---------

Emission Results and Health Benefits for Project: NezPerce 03-20 Kenworth

Emission Results

Health Benefits

Emission Results [?]

Here are the combined results for all groups and upgrades entered for your project.¹

<i>Annual Results (short tons)²</i>	NO_x	PM2.5	HC	CO	CO₂	Fuel³
Baseline for Upgraded Vehicles/Engines	0.053	0.005	0.006	0.024	16.5	1,463
Amount Reduced After Upgrades	0.047	0.005	0.006	0.022	0.0	0
Percent Reduced After Upgrades	88.6%	97.4%	89.7%	89.4%	0.0%	0.0%

<i>Lifetime Results (short tons)²</i>						
Baseline for Upgraded Vehicles/Engines	0.159	0.016	0.019	0.072	49.4	4,389
Amount Reduced After Upgrades	0.141	0.015	0.017	0.065	0.0	0
Percent Reduced After Upgrades	88.6%	97.4%	89.7%	89.4%	0.0%	0.0%

<i>Lifetime Cost Effectiveness (\$/short ton reduced)</i>						
Capital Cost Effectiveness ⁴ (unit & labor costs only)	\$830,245	\$7,602,174	\$6,705,046	\$1,807,038	\$0	
Total Cost Effectiveness ⁴ (includes all project costs)	\$830,245	\$7,602,174	\$6,705,046	\$1,807,038	\$0	

¹ Emissions from the electrical grid are not included in the results.

² 1 short ton = 2000 lbs.

³ In gallons; fuels other than ULSD have been converted to ULSD-equivalent gallons.

⁴ Cost effectiveness estimates include only the costs which you have entered.

<i>Remaining Life</i>	2003 Kenworth T8: Short Haul - Single Unit Class 8	3 years
------------------------------	---	---------



Nez Perce Tribe VW Environmental Mitigation Trust Agreement

Attachment B

Mitigation Action Management Plan Including Budget and Implementation and Expenditures Timeline (5.2.4)

Milestone	Date
Trust Notifies Nez Perce Tribe of Mitigation Funds Available to Tribe	Jul. 1, 2019
Nez Perce Tribe Air Quality Program, With Approval of the Nez Perce Tribe Executive Committee, Submits Mitigation Proposal to Trust	Aug. 30, 2019
Trust Acknowledges Receipt of Proposal and Funding Direction for Payment Advance	Sep. 30, 2019
Nez Perce Tribe Solicits Bids for Vehicle Replacements	Oct. 15, 2019
Nez Perce Tribe Solicits Bids for Electric Vehicle Charging Station	Oct. 15, 2019
Trust Allocates Share of Funds as Payment Advance for Approved Project	Nov. 13, 2019
Trust Disburses Mitigation Funds for Round 2	Nov. 13, 2019
Nez Perce Tribe Issues Purchase Orders for Replacement Vehicles	Dec. 15, 2019
Nez Perce Tribe Enters Into Contract for Electric Vehicle Charging Station	Dec. 15, 2019
Replacement Vehicles are delivered, registered, licensed	Feb. 28, 2020
Light Duty Zero Emission Electric Vehicle Charging Station - Installation Start	Jan. 1, 2020
Light Duty Zero Emission Electric Vehicle Charging Station - Installation Complete	Apr. 15, 2020
Nez Perce Tribe Air Quality Program provides detailed invoices for all claimed project costs, documentation for emission reduction estimates, requires certification documents to Trustee for Final Accounting	May 13, 2020
Nez Perce Tribe Air Quality Program Submits Final Report	May 13, 2020

Budget, below.

Project Budget

Period of Performance: Second Funding Cycle

Budget Category	Total Cost	Tribe Cost-Share	Trust Funds
Project Administration			
Air Quality Staff (120 hours Coordinator; 120 hours Specialist) (Equivalent 0.1154 full time employment (FTE))	\$9854	0	\$9854
Fringe Benefits (FICA \$611 @ 6.2%; FICA-Medical \$143 @ 1.45%; SUTA \$75 @ .753%; Workers Compensation \$296 @ 3%)	1125	0	1125
Equipment			
Acquisition of Kenworth T-800 Diesel Truck	117,106	0	117,106
Acquisition of Ford F-450 Diesel Truck	59,515	0	59,515
Acquisition of Bed for F-450 Truck	8200	0	8200
Light Duty Zero Emission Electric Vehicle Fast Charging Station at Kamiah	42,609	7035	35,574
Other			
Disable/Disposal/Hauling - 2 vehicles	2170	0	2170
Shelter for Electric Vehicle Charging Station	1400	1400	0
Charging Station Electricity Development	20,000	20,000	
Total Direct Costs	\$261,979	\$28,435	\$233,544
Indirect Charges (per FY19 federal Indirect Cost Rate Agreement)	3616		3616
Project Totals	\$265,595	\$28,435	\$237,160
Percentage	100%	11 %	89%

Administrative costs consist of personnel services. Air Quality Program personnel are employees of the Nez Perce Tribe, not consultants. The hours listed for each employee represent the amount of time the employees will devote to this project, expressed as the number of hours per average wages of \$41 per hour and including standard governmental fringe benefits per allocated wages.

The Air Quality Program Coordinator and Specialist will be responsible for the following activities to implement the Environmental Mitigation Action:

1. Issue requests for proposals for new vehicles, evaluation quote proposals, enter into contracts and purchase orders, etc. to acquire new vehicles, install new vehicles, register, title, inventory and account for new vehicles;
2. Contracting with a qualified firm for disabling and disposal of the vehicles to be replaced;
3. Issue requests for proposals for installation of an electric vehicle charging station; monitor installation including labor, materials and project oversight;
4. Implement all other aspects of the Environmental Mitigation Action, including providing detailed invoices for all claimed project costs, documentation for emission reduction estimates, and required certification documents to Trustee for final accounting.

Trust Allocation

The Trust notified the Nez Perce Tribe that the Tribe is eligible for \$237,160 from the Environmental Mitigation Trust in its second funding cycle. The Nez Perce Tribe will provide \$28,435 for a cost-share in the project and is committed to covering any unexpected additional costs.



Nez Perce Tribe VW Environmental Mitigation Trust Agreement

Attachment C

Plan for Reporting on Eligible Mitigation Action Implementation

5.2.11

The Nez Perce Tribe Air Quality Program will report to the Trustee in Eligible Mitigation Action implementation on a six-month basis by providing detailed written reports to the Trustee on or before the first six-month period ending on May 13, 2020. In the event the project closes all activities and expends all Trust funds prior to this date, then the May 13, 2020 report will be submitted as the Final Report.

If the project is not closed out within the first six-month period, then the next reports will be submitted to the Trust on or before July 30, 2020 and January 30, 2021. Interim or final reports will include all actions taken by the Air Quality Program as the Lead Agency, all claimed project costs, documentation for emission reduction estimates, and required certification documents to the Trustee.



Nez Perce Tribe

VW Environmental Mitigation Trust Agreement

Attachment D

Cost Estimates

5.2.6

Cost estimates from potential vendors for each proposed expenditure exceeding \$25,000 are attached to this Attachment D. Please note that the quote for the Kenworth T-800 Truck amount of \$117,106 represents a reduced governmental rate package; this amount is lower than the "Total Equipment Price" listed in the quote.

From: Johna Boulafentis
To: johna.boulafentis
Subject: FW: New KW T800
Date: Wednesday, August 28, 2019 12:03:00 PM
Attachments: [image001.png](#)
[Presentation Package \(72\).pdf](#)
Importance: High

From: Dirk Booth [<mailto:dbooth@kwsco.com>]
Sent: Monday, August 12, 2019 11:16 AM
To: Mike Key
Subject: New KW T800

Hi Mike,

Attached please find our presentation package for a new Kenworth T800 tractor. I spec'd this off the original build sheet of your 2003 unit VIN# 395284. As I mentioned I spec'd a 13-speed transmission, a wide track front axle for tighter turning radius, and Kenworth Airglide 400 suspension, replacing the Airglide 200 which is no longer available. An optional 18-speed transmission replacing the 13-speed will add \$303 to the cost.

Thank you Mike for allowing us to give you a quote. Feel free to contact me with any questions.

DIRK BOOTH

TRUCK SALES

O:208.746.7087 | C: 509.370.2209

dbooth@kwsco.com

Lewiston



KenworthSalesCo.com

[Facebook](#) | [Instagram](#) | [Twitter](#) | [LinkedIn](#)

This message constitutes a confidential and proprietary communication between Kenworth Sales Company and the intended recipient. Any use, forwarding, reproduction or publication is expressly prohibited unless consented to by the original sender in writing. Sender's signature does not constitute a signed writing for purposes of binding a contract. Sender is not authorized, nor have the intent to form a contract hereby.



Customer Quote

Equipment

Quantity:	1	
Truck Price:	\$209,463	
Dealer Options:	\$0	
Extended Warranty:	\$0	
Equipment Price:	\$152,908	
Surcharges Not Subject to Discount:	\$0	
Options Not Subject to Discount:	\$0	
Factory Freight Cost:	\$2,475	
 Total Equipment Price:		<u>\$155,383</u>

NET Sale Price: **\$116,653**

Miscellaneous

FET Tire Credit:	\$0
Net Chassis FET:	\$0
State Tax:	\$0
Body/Trailer/Accessories FET:	\$0
Fees:	\$150
Other:	\$0

Quotation Total: **\$116,803**

This quotation worksheet is provided to aid dealers in their pricing efforts. Since PACCAR Inc and its truck divisions have no control over data input and various transactional circumstances that may affect the FET calculation, it is not to be considered tax advice. The dealer should consult his own tax advisor for the proper calculation of any taxes under the variety of circumstances, which may occur.



Kenworth Sales Company - Spokane (T056)
 6420 East Broadway
 Spokane, Washington 99212

Nez Perce Tribe
 PO Box 365
 Lapwai, Idaho 83540
 United States of America

Dirk Booth
 Phone:
 Email: dbooth@kwsco.com

Mike Key
 Phone:
 Email:

Vehicle Summary

	Unit		Chassis	
Model:	T800 Series Conventional.	Fr Axle Load (lbs):		13220
Type:	TRACTOR	Rr Axle Load (lbs):		40000
Description 1:		G.C.W. (lbs):		80000
Description 2:				
	Application	Road Conditions:		
Intended Serv.:	Local pickup & delivery: Vehicles	Class A (Highway)		90
	which			
Commodity:	General freight.	Class B (Hwy/Mtn)		10
		Class C (Off-Hwy)		0
		Class D (Off-Road)		0
	Body	Maximum Grade:		6
Type:		Wheelbase (in):		220
Length (ft):	0	Overhang (in):		60
Height (ft):	0	Fr Axle to BOC (in):		74
Max Laden Weight (lbs):	0			
	Trailer	Cab to Axle (in):		146
		Cab to EOF (in):		206
No. of Trailer Axles:	2	Overall Comb. Length (in):		819
Type:	Flatbed			
Length (ft):	48			
Height (ft):	13.5	Special Req.		
Kingpin Inset (in):	24	U.S. Domestic registry, 50-state.		
Corner Radius (in):	2			
	Restrictions			
Length (ft):	75			
Width (in):	102			
Height (ft):	13.5			

Approved by: _____

Date: _____

Note: All sales are F.O.B. designated plant of manufacture.



Sales Code	Std/Opt	Description	Weight
Model			
0000800	S	T800 Series Conventional. Elastomer bushed front spring pins & heavy-duty shock absorber brackets, 16mm. fasteners from rear cab support to end-of-frame, except tractor taper crossmember. Vinyl inside sunvisors, driver side includes strap & mirror, rider side includes strap; Under-dash center console w/ 2 cup holders, 2-12V outlets & a storage compartment, Glove box door with locking latch.	15,004
0070066	S	T800: Sloped Hood.	0
0080055	O	CARB Idle Emissions Reduction - Cummins	0
0090000	S	Non-Sleeper w/rear axle capacity less than 59K.	0
Engine & Equipment			
0123690	O	X15 485 2017 485@1800 449@2000 1650@1150 w/Intebrake, Diagnostic Plug for data link, Oil Cooler, Aluminum Flywheel Housing. Vocational, Performance Series N09260 P14 64....Maximum Accelerator Pedal Ve N09440 P11 NO....Engine Protection Shutdown ((N09460 P06 NO....Gear Down Protection (P06) N09300 P19 64....Maximum Cruise Speed (P19) N09720 P230 YES...Enable Hot Ambient Automatic N09500 P02 NO....Cruise Control Auto Resume ((N09520 P04 NO....Auto Engine Brake in Cruise N09480 P26 1400..Max PTO Speed (P26) N09580 P32 1.....Timer Setting (P32) N09680 P33 NO....Idle Shutdown Manual Overrul N09560 P520 YES...Enable Idle Shutdown Park Br N09600 P233 YES...Enable Impending Shutdown Wa N09780 P47 80....High Ambient Temperature Thr N09740 P46 0.....Low Ambient Temperature Thre N09200 N205 120...Standard Maximum Speed Limit N09620 P234 0.....Timer For Impending Shutdown N09360 N203 252...Reserve Speed Function Reset N09640 P516 0.....Engine Load Threshold (P516) N09400 N206 10....Maximum Active Distance (N20 N09420 N201 0.....Reserve Speed Limit Offset ((N09760 P56 60....Intermediate Ambient Tempera N09240 P13 120...Hard Maximum Speed Limit (P1 N09380 N202 0.....Maximum Cycle Distance (N202 N09220 N207 0.....Expiration Distance (N207) N09540 N209 0.....Expiration Distance (N209)	300
1000151	S	PremierSpec	0
1000683		Effective VSL Setting 65.0 MPH or Greater (USA)	0
1000857	S	Engine Idle Shutdown Timer Enabled	0

Price Level: January 1, 2019

Deal:

Printed On: 8/12/2019 10:57:26 AM

Date: August 12, 2019

Quote Number: QUO-433995-T6K3Y0

Sales Code	Std/Opt	Description	Weight
1000859	O	Enable EIST Ambient Temp Overrule	0
1000891		Eff EIST NA Expiration Miles	0
1002080	O	Air compressor: Cummins 18.7 CFM, Naturally Aspirated for Cummins X15 engines	0
1051086	S	Air cleaner: Powercore engine mount 10 in. w/constant torque SS clamps, pop-up air restriction indicator. Holds 10% more fine dust than 2500. Pop-up indicator is standard.	0
1105221	O	Fan Hub: Horton On/Off for X15	0
1125640	S	Cooling module: T8SH/T8B/W9S 1440 square inches. Includes aluminum radiator core, aluminum charge air cooler, translucent surge tank and washer bottle, silicone hoses, and extended life coolant. Drain valve is not available w/Allison transmissions.	0
1160208	O	Radiator bug screen mounted between hood & grille.	2
1247179	O	Exhaust: 2017 EPA RH Under Cab DPF/SCR w/ Dual Side of Cab Tailpipes for Daycabs, Extended Daycabs, or Modular Sleepers. *LH Pipe is not functional for the exhaust.	160
1290236	O	Tailpipe: 5 in. dual 36 in. 45 degree curved.	0
1321109	S	Fuel Filter:PACCAR Standard Service Interval Fuel/Water Separator. 2017 and Later Emissions	0
1321200	O	Run Aid:None *For Fuel Filter	0
1321300	S	Start Aid:None *For Fuel Filter	0
1816260	S	Alternator: PACCAR 160 amp, brush type	0
1821215	O	Batteries: 4 PACCAR GP31 threaded post (700-730) 2800-2920 CCA dual purpose.	57
1836100	S	Starter: PACCAR 12 volt electrical system. W/ centralized power distribution incorporating plug-in style relays. Circuit protection for serviceability, 12-volt light system w/circuit protection circuits number & color coded.	0
1900082	O	Multi-function engine connector for body builder interface for Cummins.	0
Transmission & Clutch			
2058444	O	Transmission: Fuller RTLO16913A 13-speed w/oil cooler & pump. Standard with synthetic lubricant. Includes severe-duty pilot bearing on all class 8 models. *Torque Limit: 1650 pound-feet.	8
2250501	O	Clutch: Eaton 15-1/2 in. Advantage Easy-Pedal to 1700 ft-lb, Ceramic, 4-Paddle	0
2405405	O	Driveline: 2 Dana 1810 heavy-duty 1 centerbearing *Heavy duty is 1810HD series.	99
2429102	O	Chassis will not be fitted w/transmission PTO. (Prevents ECU F/Interfering w/ PTO Only).	0

Price Level: January 1, 2019

Deal:

Printed On: 8/12/2019 10:57:26 AM

Date: August 12, 2019

Quote Number: QUO-433995-T6K3Y0

Sales Code	Std/Opt	Description	Weight
2460042	O	14 in. Eaton Fuller high capacity oil to water cooler standard for transmission 1550-2250 lb-ft, 18-speed AutoShift.	0
Front Axle & Equipment			
2503467	O	Dana Spicer E-1462W Front Axle rated 14.6K 3-1/2in. drop, wide track for better turning radius.	50
2601608	O	Front Brakes: 18K Bendix RSD HP-ES S-Cam 16.5x6 in. drum brake , Max GAWR 18K, with Cast Spider.	-44
2690035	O	Front Brake Drum: 22,000 lbs. 16-1/2x6 in. Cast.	104
2702500	O	Front Hub: iron hub pilot 14,600 lbs. 11-1/4 in. bolt circle. For use w/ air disc brakes. Consider wheelguards (5850002) w/ aluminum wheels.	48
2741970	S	ConMet PreSet Plus Hub package; front axle.	0
2750001	S	Hubcap: front vented.	0
2765001	O	Front Auto Slack Adjuster.	0
2864019	O	Front Springs: Taperleaf 14.6K w/shock absorbers 2-leaf. With maintenance-free elastomer spring pin bushings. Standard with rubber pins. Not available on W900L or W900S.	25
2893881	O	Single power steering gear: 16K TRW TAS85 W900B/W990 available, but not available W900S, W900L or T3.	18
2900615	O	Threaded bushings for taperleaf springs 12K - 14.6K replacing rubber: T6/T8, W900B, W990. W9L gets as standard: code not required. Not available with W9S. 13K - 14.6K for T370.	0
Rear Axle & Equipment			
3124403	O	Dual Dana Spicer DSP41 rear axle rated at 40K. (DSP40 w/ heavy-wall housing) w/ 11mm housing and 1.88in. shaft diameter. Tandem rear axles.	113
3200433	O	Rear Axle Ratio - 4.33.	0
3304012	O	Rear Brake: Bendix RSD 16.5X7 Dual 46K Capacity Reduced Stopping Distance Tractor Only. RSD-Compliant HP-ES S-Cam, tandem axle drum brake.	24
3392005	S	Dual Rear Brake Drums: cast.	0
3403460	O	Dual Rear Hubs: Iron hub pilot 11-1/4 in. BC.	104
3441972	S	ConMet PreSet Plus Hub package; dual rear axle.	0
3465002	S	Dual Rear axle automatic slack adjusters.	0
3485207	O	Spring Brake: 3030 long stroke dual 30 square inches travel; replaces standard 2-1/2 in. travel. Helps keep brakes in adjustment longer.	4

Sales Code	Std/Opt	Description	Weight
3495225	O	FMVSS-136 Stability Control Schedule Review Chassis meets FMVSS-136 requirements and must be equipped with Electronic Stability Control. Reference Option code placed on order.	0
3495229	O	Bendix 4S/4M anti-lock brake system w/ air traction control (ATC) & electronic stability program (ESP) for tractor.	11
3500037	O	Interaxle driveline:1 Dana 1710 Series	0
3730030	S	Rear suspension: Tandem Kenworth Airglide 400 40K 52 in. axle spacing. Air suspension w/ 9 in. ride height. Includes air suspension dump valve.	0
Tires & Wheels			
4071633	O	Front Tires: Bridgestone R284 Ecopia 11R24.5 14PR	20
4277519	O	Rear Tires: Bridgestone M710 Ecopia 11R24.5 14PR. 43.8 in. diameter, drive. 20.4 in. SLR. Smartway certified. Code is priced per pair of tires.	128
4900008	O	Rear Tire Quantity: 8	0
5045275	O	Front Wheel: Alcoa 98U63 24.5X8.25 AL Ultra ONE Wheel.	-34
5242310	O	Rear Wheel: Accuride 28827 24.5x8.25 steel Steel Armor[™] powder coat, hub-pilot mount. 8000lb. maximum rating. 2-hand hole. Code is priced per pair of wheels.	140
5853906	O	Powder coat white steel wheel. Use in conjunction with front, dual front, rear, spare or lift axle wheel code(s). All wheels on chassis must have same finish color.	0
5900008	O	Rear Wheel/Rim Quantity: 8	0
Frame & Equipment			
6056400	O	Frame Rails: 10-3/4 x 3-1/2 x 3/8in. Steel 285in. to 336 in. Truck frame weight is 3.48 lb.-in. per pair of rails. Section modulus is 17.80, RBM is 2,132,000 in.-lbs per rail. Frame rail availability may be restricted based upon application, axle/suspension capacity, fifth wheel setting, or component/dimensional specifications. The results of the engineering review may result in a change to the requested frame rail. If a change is required Kenworth Application Engineering will advise the dealer of the appropriate material specification for a substitute rail.	351
6301437	O	Bumper: Straight steel, painted channel. Requires a bumper setting code.	50
6319485	O	48.5 in. Bumper setting. Requires a bumper code.	0
6324025	O	Front tow hook: Center mounted, cast. Requires iron front drive brackets.	28
6390103	S	Front mudflaps.	0
6390312	O	Brackets: Iron front spring drive. Included with front spring capacity of 16,000 lbs or greater; code not required.	47

Sales Code	Std/Opt	Description	Weight
6400636	O	Battery box cantilever aluminum BOC with fiberglass cover.	8
6409901	S	Battery box location: LH Side.	0
6451090	S	T470,C5, T6, T8 non-polished DPF/SCR or CNG cover diamond plate w/ step. For use w/ 2010 or later exhaust systems. For T8, use extended length non-polished battery box on opposite rail to match the length of under cab components. End plates will be painted standard black frame color.	0
6543949	O	Fifth Wheel: ILS>40K air Hol FW35M824XL00 24 in. slide, 8 in. height. Outboard mounting angles, 55K vertical rating, LH release. Air slide control valve standard in dash. Accommodates a 2 in. SAE kingpin. Requires some style of trailer connections.	566
6679915	O	Customer-installed bulkhead and/or headache rack.	0
6679975	O	Frame access package recommended. Dealer contact declines.	0
6680000		FifthWheelRearFixedSetting FW rear/fixed setting behind ahd 0 in	0
6721102	S	Rear mudflap arms: Betts B-25 standard-duty, straight. Includes B1732 mounting brackets as standard.	0
6722000	S	Rear mudflap shields: White plastic antisail w/ Kenworth logo.	0
6743111	O	Tractor Taper w/ crossmember. Non-towing end-of-frame configuration.	13

Fuel Tanks & Equip

7212100	O	Fuel Tank: 100 US gallon 24.5in. aluminum under add. Class 8 fuel tanks w/ o locking caps include an anti-siphon device on the filler neck. Multiple tank installations include a fuel equalization system w/ dual draw and return lines with a splitter valve located within 6 inches behind the cab. Single draw and return is an option in some cases.	114
7214100	S	Fuel Tank: 100 US gallon 24.5in. aluminum BOC replace. Class 8 fuel tanks w/ o locking caps include an anti-siphon device on the filler neck.	0
7722019	O	Medium round DEF tank. 20.7 gallons of usable volume. The DEF tank will be located on the side you specified. If you have specific configuration or body builder concerns, please utilize the Custom Frame Layout option. Standard capacity is calculated by fuel capacity of the vehicle and will accommodate two diesel fill-ups for every DEF fill-up. For 1:1 DEF fuel fill ratio, add 7889204.	32
7889203	S	Standard DEF to fuel fill ratio: 2:1 or greater.	0
7889245	S	Anti-siphon device swaged in place. For any number of fuel tanks.	0
7889604	S	DEF tank location is on the LH.	0
7920100	O	Location: 100 gal fuel tank LH under cab	0

Price Level: January 1, 2019

Deal:

Printed On: 8/12/2019 10:57:26 AM

Date: August 12, 2019

Quote Number: QUO-433995-T6K3Y0

Sales Code	Std/Opt	Description	Weight
7930100	S	Location: 100 gal fuel tank RH behind cab	0
Cab & Equipment			
8024310	S	Cab: Curved Glass Conventional. Cab Includes aluminum & fiberglass fully hucked cab w/ all aluminum bulkhead doors & continuous stainless steel piano-style door hinges. Single electric horn standard. Incandescent exterior lights include diagnosable bulb detection and warning. Trailer cable on tractors includes integrity detection. Standard features include multiplex wiring for interior lights, automated pre-trip inspection (excluding T3 series), short and open check diagnostics. Warning alarm will sound when lights are left on.	0
8090103	S	Hood: Sloped Metton Hood W/ Grille & Shell Use For T800B 1-Piece Requires Engine Mounted Air Cleaner, 1440 Square In. Radiator & 2007+ Engines.	0
8108010	S	Cab heater: W/integral defrosters & A/C 45,000 btu cab heater. No sleeper heater/AC. Includes 5 mode rotary control. T660 include filter media.	0
8201013	S	Steering wheel: 18 in. 4-spoke.	0
8208496	O	Three spare switches: Wired to power.	0
8282004	S	KW Driver Information Center: Includes fuel economy, RPM display, trip information, truck information, diagnostics, gear display, alarm clock.	0
8282009	S	Instrument package: Includes speedometer, tachometer, fuel gauge, engine coolant temperature gauge, engine oil pressure, voltmeter. Class 8 also includes primary & secondary air reservoir gauges & an air application gauge. DEF level gauge and warning lamp are included with 2010+ engines. Engine hour meter and outside air temperature readouts are standard. Primary read out will be MPH. Add 8240620 to switch primary scale to KPH in Canada.	0
8331100	S	Cab interior: Splendor. Includes smooth upholstered side & back panels w/stitched accent lines, upholstered door pads, full vinyl headliner, black dash panels & black rubber floormats.	0
8343304	S	Interior color: Slate Gray w/trim Dark Slate Gray	0
8410091	S	Driver seat: Kenworth Air cushion Plus HB cloth. Standard features includes 7 in. fore and aft slide adjustment w/isolator, 6-23 degree recline, air suspension with cover, dual armrests, and single chamber air lumbar support. Seat cushion is 20 inches wide w/ 2-position tilt and 2-position front cushion extension. Seat material has a horizontal stitch pattern and is 2-tone in color. Seat back is carpeted and includes a map pocket. Seat is manufactured by National. Includes inside visor and retractable 3-point matching seat belts. Grey seat belts.	0
8460091	O	Rider seat: Kenworth Air cushion Plus HB cloth. Standard features includes 7 in. fore and aft slide adjustment w/isolator, 6-23 degree recline, air suspension with cover, dual armrests, and single chamber air lumbar support. Seat cushion is 20 inches wide w/ 2-	17

Price Level: January 1, 2019

Deal:

Printed On: 8/12/2019 10:57:26 AM

Date: August 12, 2019

Quote Number: QUO-433995-T6K3Y0

Sales Code	Std/Opt	Description	Weight
		position tilt and 2-position front cushion extension. Seat material has a horizontal stitch pattern and is 2-tone in color. Seat back is carpeted. Seat is manufactured by National. Includes inside visor and retractable 3-point matching seat belts. Grey seat belts.	
8490110	S	Seat color: Dark Slate Gray.	0
8497005	O	Air line fitting: At driver seat. Customer-installed air chuck.	4
8601422	O	Kenworth Radio with AM/FM/WB/CD/USB and Bluetooth	4
8601880	O	CB Radio: Cobra 29. Includes weatherband w/header mounted quick release. Includes transceiver & separate speaker remote-mounted in headliner & dual CB antennas. Includes sound tracker & illuminated panel.	11
8700168	S	Non-self cancelling turn signal: W/column-mounted headlight dimmer switch & intermittent wiper control.	0
8700186	S	Electric LH & RH door locks.	0
8700663	S	Kenworth TruckTech+ The Kenworth Remote Diagnostics system provides the Worlds Best reporting of engine and aftertreatment fault codes, as well as enhanced support for the truck owner through rapid communication of fault severity and recommended actions. This option is Standard on all Heavy Duty Kenworths with a PACCAR MX engine, Cummins X15 engine, PX engine or Natural Gas engine. Optional on Medium Duty Kenworths.	0
8800271	S	Long grabhandle RH side of cab.	0
8800373	S	Long grabhandle LH side of cab.	0
8800400	S	Grabhandle: LH inside door frame above dash.	0
8800401	S	Grabhandle: RH inside door frame above dash.	0
8832115	S	Daylite Door: LH/RH includes RH peeper window	0
8841303	O	Single Rectangular Air Horn 23 in. LH Top of Roof Includes Air Horn Cover.	0
8850300	S	Look-Down, Pass. Door, Stainless 8.5x4.4	0
8866100	S	Mirror: Dual Prutsman fixed heated mirrors 7 in. x 16 in. includes 7-1/2 in. convex mirror, RH.	0
8869005	S	Mirror brackets 8-1/2 ft load width.	0
8871438	S	Rear Cab Stationary Window 17 in. x 36 in.	0
8879200	S	Manual LH & electric-powered RH door window. Switch located on door.	0
8890105	O	Two-Piece Roped-In Windshield, W/ Curved Glass.	2

Sales Code	Std/Opt	Description	Weight
8890134	S	Exterior aerodynamic sunvisor w/ integral marker lights.	0
Lights & Instruments			
9010802	S	Headlamps: Dual Rectangular, extended life halogen	0
9026205	O	Marker Lights: Five aerodynamic, LED mounted in sunvisor.	0
9030010	S	Turn Signal Lights: Mounted on fender	0
9030052	S	LED Stop,Turn,Tail: With Two LED Backup Lights and With An LED License Plate.	0
9042542	O	Fog Light: With Clear Lens. Does Not Include Rock Screens on T680.	4
9090039	S	Marker Lights: Interrupter Switch. Included in Turn Signal For All Models Except T3. The T3 Switch Is In The Dash.	0
9090049	O	Omit Brake Light with Engine Brake. Can only be selected when chassis also has engine brake. Cannot be used with options to delete engine brake.	0
9090845	O	Circuit Breakers: Replacing fuses. Does not apply to any 5-amp fuse box position. Brakers include stop/brake/turn, tail lamp, high & low beams, marker/clearance lamps, horn, fuel heat, gauges, air dryer, HVAC controls, panel lamps. Some circuits will remain fuses.	0
Air Equipment			
9101215	S	Air Dryer Bendix AD-IS heated Puraguard	0
9108001	S	Moisture ejection valve w/ pull cable drain.	0
9110071	O	Tractor kit: Center frame-mounted w/ hosetenna. Includes composite gladhand/light plug holder. Kit includes dash mounted trailer air supply valve, trailer hand control valve, and hoses/fittings for the valves. Dash mounted parking brake valve and tractor protection valve are standard. Air lines are detachable at one end only, light lines are detachable at both ends. Conspicuity components are standard.	24
9121043	O	Phillips 15ft coiled light line w/ metal plugs & 6 in. lead. Must code for tractor kit.	4
9121115	O	Coiled air & light lines replacing straight lines Included in tractor kit. 15ft working length.	2
9140020	S	Nylon air tubing in frame & cab, excluding hoses subject to excessive heat or flexing.	0
9140328	O	Trailer ABS electric supply through SAE J560 7-pin connector per TMC RP137).	0
9140700	O	Standard hosetenna Bracket Location. Hosetenna bracket will be located plus or minus six inches from standard location of eight inches.	0



Sales Code	Std/Opt	Description	Weight
Extended Warranty			
9200021	S	Base Warranty - Standard Service Heavy Duty 12 months / 100,000 miles / 160,000 km.	0
Miscellaneous			
9400072	O	Ship to Dealer.	0
9409852	O	GHG Secondary Manufacturer: Does Not Apply	0
Promotions			
Paint			
9700000	O	Paint color number(s). N9702 A - L0006 WHITE N9770 BUMPER L0006 WHITE N9720 FRAME N0001 BLACK	0
9943001	O	Bumper Painted Color A	0
9943050	S	Day Cab Standard Paint	0
9944820	S	1 - Color Paint - Day Cab Color will be White if no other color is specified.	0
9965510	O	Base coat/clear coat. The Kenworth Color Selector contains additional instructions, as well as information on Kenworth paint guidelines and surface finish applications. Kenworth is standard with Dupont Imron Elite paint.	0

Order Comments



Total List Price (W/O Freight & Warranty & Surcharges)	\$209,463
Marketing and Service Support Fee	\$640
Prepaid Freight	\$2,475
Total Surcharge/Options Not Subject To Discount	\$0
Total Weight	17,622

Prices and Specifications Subject to Change Without Notice.

Unpublished options may require review/approval.
Dimensional and performance data for unpublished options may vary from that displayed in CRM.

PRICING DISCLAIMER

While we make every effort to maintain the web site to preserve pricing accuracy, prices are subject to change without notice. Although the information in this price list is presented in good faith and believed to be correct at the time of printing, we make no representations or warranties as to the completeness or accuracy of this information. We reserve the right to change, delete or otherwise modify the pricing information which is represented herein without any prior notice. We carefully check pricing specifications, but occasionally errors can occur, therefore we reserve the right to change such prices without notice. We disclaim all liability for any errors or omissions in the materials. In no event will we be responsible for any damages of any nature whatsoever from the reliance upon information from these materials. Please check your order prebills to confirm your pricing information

HORIZONTAL DIMENSIONS

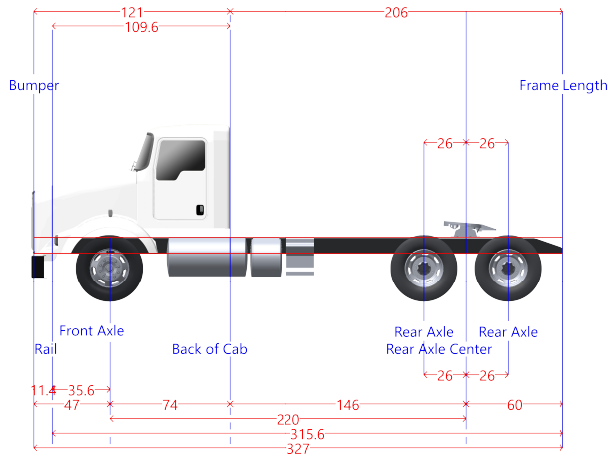

Dimension	Measurement	Start	End
Axle Spacing	52	194	246
Bumper to Back of Cab	121	-47	74
Bumper to Front Axle	47	-47	0
Bumper to Front Frame	11.4	-47	-35.6
Cab to End of Frame	206	74	280
Cab to Rear Axle	146	74	220
Effective Bumper to Back Of Cab	121	-47	74
Frame Length	315.6	-35.6	280
Front Axle to Back of Cab	74	0	74
Front of Frame to Axle	35.6	-35.6	0
Load Space	206	74	280
Overall Length	327	-47	280
Overhang	60	220	280
Pusher Offset #1	26	194	220
Pusher Offset #2	26	194	220
Pusher Offset #3	26	194	220
Tag Offset	26	220	246
Wheelbase	220	0	220

VEHICLE WEIGHT RATING

FRONT AXLE COMPONENTS

Component	Sales Code	Description	Ratings
Axle	2503467	Dana Spicer E-1462W Front Axle rated 14.6K	14,600
Springs	2864019	Front Springs: Taperleaf 14.6K w/shock absorbers	14,600
Power Steering	2893881	Single power steering gear: 16K TRW TAS85	16,000
Hubs, Drums	2702500	Front Hub: iron hub pilot 14,600 lbs.	14,600
Brakes	2601608	Front Brakes: 18K Bendix RSD HP-ES S-Cam 16.5x6	18,000
Tires	4071633	Front Tires: Bridgestone R284 Ecopia 11R24.5 14PR	13,220
Wheels	5045275	Front Wheel: Alcoa 98U63 24.5X8.25 AL	14,800

Requested Front (Lbs): 13,220
 Minimum: 8,000
 Maximum: 13,220

The front axle weight rating cannot exceed 13220

REAR AXLE COMPONENTS

Component	Sales Code	Description	Ratings
Axle	3124403	Dual Dana Spicer DSP41 rear axle rated at 40K.	40,000
Hubs, Drums	3403460	Dual Rear Hubs: Iron hub pilot 11-1/4 in. BC.	52,000
Service Brakes	3304012	Rear Brake: Bendix RSD 16.5X7 Dual 46K Capacity	46,000
Spring Brakes	3485207	Spring Brake: 3030 long stroke dual 30 square	52,000
Suspension	3730030	Rear suspension: Tandem Kenworth Airglide 400 40K	40,000
Tires	4277519	Rear Tires: Bridgestone M710 Ecopia 11R24.5 14PR.	48,040
Wheels	5242310	Rear Wheel: Accuride 28827 24.5x8.25 steel	64,000

Requested Rear (Lbs): 40,000
 Minimum: 16,000
 Maximum: 40,000

The rear axle weight rating cannot exceed 40000

GROSS COMBINATION WEIGHT RATING

GCWR (lbs)	80,000
Min	53,221
Max	999,000

The Gross Combination Weight Rating rating cannot exceed 999000

Geared Speed Report (Engine Fan Off)

Configuration: T800 Series Conventional. / TRACTOR GCW: 80000
Quote/DTPO/CO: QUO-433995-T6K3Y0
Engine: 0123690 X15 485 2017 485@1800 449@2000 1650@1150
Transmission: 2058444 Transmission: Fuller RTLO16913A 13-speed
Rear Axle: 3124403 Dual Dana Spicer DSP41 rear axle rated at 40K.
Rear Tire: 4277519 Rear Tires: Bridgestone M710 Ecopia 11R24.5 14PR. | Revs/Mile: 475
Operating Conditions: 0% Rolling Resistance

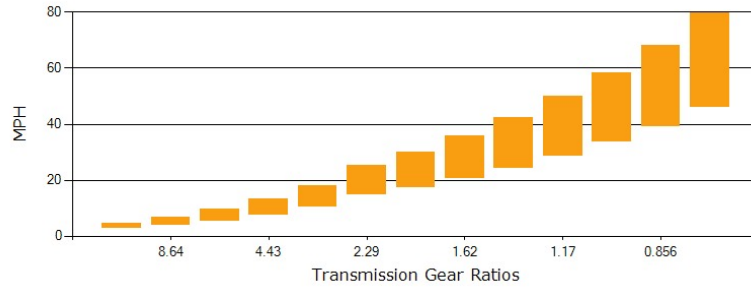

Gradability Report (Engine Fan Off)

Configuration: T800 Series Conventional. / TRACTOR GCW: 80000
 Quote/DTPO/CO: QUO-433995-T6K3Y0
 Engine: 0123690 X15 485 2017 485@1800 449@2000 1650@1150
 Transmission: 2058444 Transmission: Fuller RTLO16913A 13-speed
 Rear Axle: 3124403 Dual Dana Spicer DSP41 rear axle rated at 40K.
 Rear Tire: 4277519 Rear Tires: Bridgestone M710 Ecopia 11R24.5 14PR. | Revs/Mile: 475
 Operating Conditions: 0% Rolling Resistance

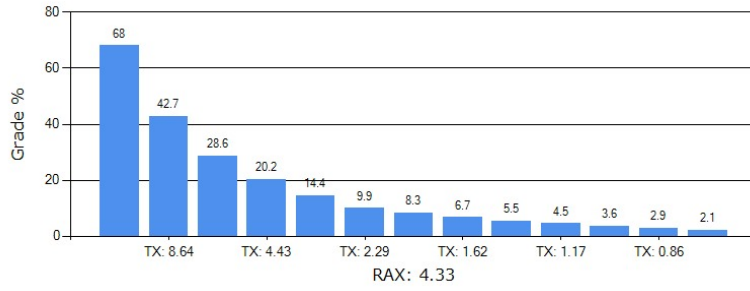

Gradability Report (Engine Fan Off)

Gear	TX-Ratio	RAX-Ratio	Peak Torque % Gradability	Peak Torque Road Speed (MPH)
1	12.31	4.33	67.97	2.73
2	8.64	4.33	42.66	3.88
3	6.11	4.33	28.65	5.49
4	4.43	4.33	20.17	7.57
5	3.23	4.33	14.35	10.39
6	2.29	4.33	9.88	14.65
7	1.95	4.33	8.27	17.20
8	1.62	4.33	6.70	20.71
9	1.38	4.33	5.54	24.31
10	1.17	4.33	4.51	28.67
11	1.00	4.33	3.64	33.55
12	.86	4.33	2.87	39.19
13	.73	4.33	2.15	45.96

Startability Report (Engine Fan Off)

Configuration: T800 Series Conventional. / TRACTOR GCW: 80000
Quote/DTPO/CO: QUO-433995-T6K3Y0
Engine: 0123690 X15 485 2017 485@1800 449@2000 1650@1150
Transmission: 2058444 Transmission: Fuller RTLO16913A 13-speed
Rear Axle: 3124403 Dual Dana Spicer DSP41 rear axle rated at 40K.
Rear Tire: 4277519 Rear Tires: Bridgestone M710 Ecopia 11R24.5 14PR. | Revs/Mile: 475
Operating Conditions: 0% Rolling Resistance

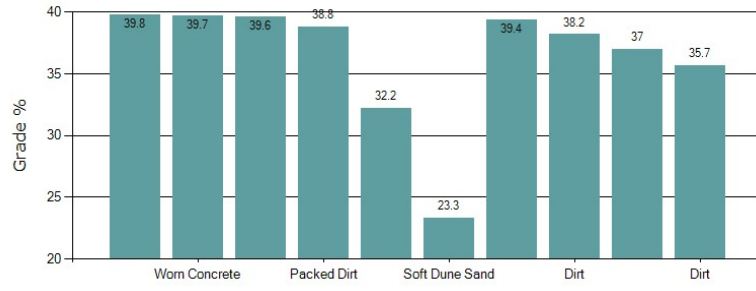



2019 Chassis Cab F-450 XL

Have vehicle
questions?



Payment

Base MSRP ^{S1}	\$41,555
Total of Options ^{S4}	\$17,365
Destination Charges ^{S17}	\$1,595
Total MSRP ^{S16}	\$60,515
Available Incentives ^{S3}	-\$1,000

Ford Credit Retail Bonus Customer Cash

Program #13558: \$1,000.00 Ford Credit Bonus cash requires Ford Credit financing. Not all buyers will qualify. Take new retail delivery from dealer stock by 09/30/2019. See dealer for complete details.

Amount: \$1,000, Offer Valid: Jul 2, 2019-Sep 30, 2019

Estimated Net Price^{S5}

\$59,515



\$831 Monthly Payment³⁰ Purchase based on \$6,052 down payment, 84 month term and 7.9% APR, \$0 trade-in-value



Dealer Information

Joe Hall Ford
1617 21st Street
Lewiston, ID83501



Showing the nearest Authorized Dealer for the entered zip code

Model

2019 Ford F-450 Chassis Cab XL Crew Cab®, 179" Wheelbase, 7L 4 Valve OHV Power Stroke® V8 Turbo Diesel B20 Engine, 6 Speed Automatic with SelectShift® Transmission (6R140), 4X4, 4.10 Non Limited Slip Axle, DRW

Paint^{S4}

Ingot Silver

\$0

Powertrain^{S4}

6.7L 4 Valve OHV Power Stroke® V8 Turbo Diesel B20 Engine with Manual Push-button Engine-Exhaust Braking

4X4

TorqShift® 6-speed SelectShift® Automatic Transmission (Diesel Engine)

Crew Cab®

4.10 Non Limited Slip Axle

179"

DRW

Packages^{S4}

XL Value Package

\$1,000

Power Equipment Group

\$1,125

Extra Heavy-Service Suspension Package

16,000 GVWR Package

\$0



Exterior^{S4}

19.5-inch Argent Painted Steel Wheels (DRW)	\$0
Jack - 6 Ton	\$0
Skid Plates - Transfer Case	\$100
Exterior Backup Alarm	\$140
Advanced Security Pack	\$0
Alternators - Dual	\$0
Rear View Camera and Prep Kit	\$415
LED Warning Strobes - Amber-White	\$725
Center High-Mounted Stop Lamp (CHMSL)	\$0
Spare Tire, Wheel and Jack	\$350
Manually Telescoping/Folding Trailer Tow with Power/Heated Glass, Heated Convex Spotter Mirror, Integrated Clearance Lamps/Turn Signals	\$0
225/70Rx19.5G BSW A/S Tires	\$0

Interior^{S4}

Medium Earth Gray	\$0
Cloth	\$0
Cloth, 40/Mini-Console/40 Front Seats	\$615
Carpet Delete	\$0
Integrated Trailer Brake Controller	\$270
Electronic-Shift-On-the-Fly (ESOF) - 4X4	\$185
110V/400W Outlet	\$175
AM/FM Stereo MP3 Player	\$0
SYNC®	\$0

Standard Features

Interior Features

- Air Conditioning - Manual Temperature Control
- Dash-top tray

Packages

Exterior Features

- Bumper, front - black painted steel with black lower air dam



- Dome Lamp - door-activated instrument panel switch operated with delay
- Floor Covering - black vinyl
- Grab handles - driver and front passenger and roof ride handles; front passenger (also over rear doors with Crew Cab)
- Headliner - color coordinated cloth
- Instrumentation with tachometer and Message Center including odometer, trip odometer, distance-to-empty, average fuel economy, engine hour meter and warning messages
- Instrument Cluster - 2.3" Productivity Screen
- Map lights - dual (front and rear with Crew Cab)
- Powerpoint - 12v, two instrument panel mounted
- Powerpoint, 12v - Rear (SuperCab and SuperCrew®)
- Steering Wheel - Black Molded Polyurethane
- Storage - secondary glove box
- Visors with passenger-side mirror
- Tilt/telescoping steering wheel
- Upfitter Switches
- Windshield wipers - interval control
- Audio - Auxiliary Audio Input Jack
- Audio - AM/FM Stereo, (4 Speakers)
- Seats - Front, Vinyl 40/20/40 split bench seat with center armrest, cupholder and storage
- Seats - Front, Manual Lumbar Support, Driver Side
- Seats - Rear, Vinyl 60/40 Fold-Up Bench Seat (SuperCab)
- Seats - Rear, 60/40 Flip-Up/Fold-Down Bench Seat (Crew Cab)

- Door Handles - black
- Quad Dual-Beam Halogen Headlamps
- Grille - Black bar-style
- Mirrors - Manual Telescoping Trailer Tow with Manual Glass
- LED Roof Clearance Lights
- Tow hooks - (2) front, black
- Splash Guards
- Glass - solar tinted
- Window - rear, fixed

Power and Handling

- Engine - 6.8L 3-valve SOHC EFI V10 engine
- TorqShift® 6-speed SelectShift® Automatic Transmission
- Alternator - Single, Extra Heavy-Duty, 220-amp (6.7L)
- Alternator - Single, Heavy-Duty, 240-amp (6.8L)
- Axle - Mono-beam front axle with coil spring suspension - (F-350 4X4, F-450 and F-550)
- Brakes - 4-wheel power disc brakes with Anti-lock Brake System (ABS); Hydro-boost (DRW)
- AdvanceTrac® with Roll Stability Control™ (RSC®)
- Trailer Sway Control (SRW)
- Stationary Elevated Idle Control (SEIC)
- 40 Gallon aft-axle (F-350 SRW, F-350 DRW/F-450/F-550)
- Shock absorbers - heavy duty gas
- Stabilizer bar - front
- Steering - power
- Steering damper
- Transfer Case - Manual 4-Wheel-Drive System with manual locking hubs (4x4 models only)
- Tough and Durable High-Strength Steel Frame
- Wheels - 19.5" Argent Painted Steel (DRW)
- 225/70Rx19.5G BSW A/S (6)

Safety

- Airbags - front seat front with passenger side deactivation switch (Regular Cab and SuperCab only)
- Airbags - front seat side



- Airbags - Safety Canopy® System with roll-fold side-curtain airbags
- Belt-Minder®, chime and flashing warning light on instrument cluster if belts not buckled
- Child tethers (Regular Cab, front passenger and all rear seating positions)
- Seat Belts - color coordinated with height adjustment (front outboard seating positions only)
- SOS Post Crash Alert System
- Autolamp (Auto On/Off Headlamps) with Rainlamp Wiper Activated Headlamps

Your Configuration: 2019 Ford F-450 Chassis Cab XL Crew Cab®, 179" Wheelbase, 7L 4 Valve OHV Power Stroke® V8 Turbo Diesel B20 Engine, 6 Speed Automatic with SelectShift® Transmission (6R140), 4X4, 4.10 Non Limited Slip Axle, DRW
Pricing shown for Zip code 83540 as of August 14, 2019^{S2}

Note. Information is provided on an "as is" basis and could include technical, typographical or other errors. Ford makes no warranties, representations, or guarantees of any kind, express or implied, including but not limited to, accuracy, currency, or completeness, the operation of the Site, the information, materials, content, availability, and products. Ford reserves the right to change product specifications, pricing and equipment at any time without incurring obligations. Your Ford dealer is the best source of the most up-to-date information on Ford vehicles. Disclosures through S18 apply to Search Dealer Inventory, Request A Quote, Get An Internet Price, Get A Quote, Let Us Find It For You, Build & Price and Incentives & Offers.

S1.

Manufacturer's Suggested Retail Price (also referred to as "MSRP", "Base MSRP", "Base Price" or the "Starting At" price), excludes destination/delivery charge, taxes, title, license, and registration and/or electronic filing fees, dealer fees, and total of options.

For authenticated AXZ Plan customers, the price displayed may represent Plan pricing. Not all AXZ Plan customers will qualify for the Plan pricing shown and not all offers or incentives are available to AXZ Plan customers.

S2.

Images shown are for information purposes only, and may not necessarily represent the configurable options selected or available on the vehicle. We cannot be responsible for typographical or other errors, including data transmission, display, or software errors, that may appear on the site.

S3.

Offers shown may not be available to all customers. Incentives lists are examples of offers available at the time of posting and are subject to change and expiration. Not all incentives can be redeemed together. To take advantage of rebates, incentives and/or financing offers you must take new retail delivery from dealer stock by the expiration date noted. Not all buyers will qualify for Ford Credit financing or other offers. Restrictions apply. See your local dealer for complete details.

S4.

The Option Package price and monthly payment displayed is for illustration purposes, only. Prices and monthly payments may vary based on features included in package, financing terms and availability. Some Options are not available separately. Not all Options or Option Packages are available on all vehicles. See your local dealer for details.



S5. Estimated Net Price is the Total Manufacturer's Suggested Retail Price ("Total MSRP") minus any available offers and/or incentives. Incentives may vary. Excludes taxes, title, and registration fees. For authenticated AXZ Plan customers, the price displayed may represent Plan pricing. Not all AXZ Plan customers will qualify for the Plan pricing shown and not all offers or incentives are available to AXZ Plan customers.

S6.

The payment estimator will calculate a monthly payment based on the MSRP of the vehicle you have configured, including the dealer-installed accessories. For authenticated AXZ Plan customers, the price displayed may represent Plan pricing. Not all AXZ Plan customers will qualify for the Plan pricing shown. Actual monthly payment is based on a variety of factors, including differing financing or leasing terms, accessory prices and installation costs. Financing payment calculations are estimates only, and are based on amount of down payment, APR and term. Lease payment calculations are estimates only, and are based on an annual mileage calculation determined by your dealer. A charge is assessed for any mileage driven that exceeds this limit. Lessee is responsible for \$395 lease Disposition Fee in select states. Not all buyers will qualify for financing or a lease. Contact your local Ford or Lincoln Dealer for details.

S7.

While dealer inventory is generally updated on a daily basis, there are no guarantees that the inventory shown will be available at the dealership. Mid-model-year manufacturing changes, as well as dealer-added accessories on the actual vehicle may differ from the options and features listed. Vehicles that are identified as 'Exact Matches' may have a different price or different features not represented on the site. We make every effort to provide you with the most accurate, up-to-date information, however, only your local Ford dealer can provide you with information regarding actual vehicle availability.

S8.

Dealer Accessories are defined as items that do not appear on the factory window sticker that are installed by a Ford or Lincoln Dealers. Actual Prices for all accessories may vary and depend upon your dealer. Prices DO NOT include installation or painting, which may be required for particular items. Please check with your authorized dealer for complete pricing accuracy for all accessories and parts.

Genuine Ford Accessories will be warranted for whichever provides you the greatest benefit: 12 months or 12,000 miles (whichever occurs first) or the remainder of your Bumper-to-Bumper 3-year/36,000-mile New Vehicles Warranty. Contact your local Ford, Lincoln or Mercury dealer for details and a copy of the limited warranty.

Ford Licensed Accessories (FLA) are warranted by the accessories manufacturer's warranty. Contact your Ford, Lincoln or Mercury Dealer for details regarding the manufacturer's limited warranty and/or a copy of the FLA product limited warranty offered by the accessory manufacturer.

Most Ford Racing Performance Parts are sold with no warranty. Ford Racing Performance Parts are sold "As Is", "With All Faults", "As They Stand" and without any express warranty whatsoever, unless otherwise expressly designated herein. To determine which parts come with a warranty from the original manufacturer, or from Ford Racing, please contact the Ford Racing Techline at (800) FORD788.

S9.

The "Trade-In Value" of your vehicle is an estimate, only, and many factors that cannot be assessed without a physical inspection of the vehicle may affect actual value. For purposes of this website, we use the services of a third-party vendor to provide Trade-In Value calculations. While we believe this information is reliable, we are not responsible for and do not guarantee the accuracy or reliability of the information. Please see your local Ford dealer for information regarding actual trade-in availability and value.

S10.

AXZ Plan pricing, including AXZ Plan option pricing, is exclusively for eligible Ford Motor Company employees, friends and family-members of eligible employees, and Ford Motor Company eligible partners. Restrictions apply. See your Ford or Lincoln dealer for complete details and qualifications. Ford Motor Company reserves the right to modify the terms of AXZ Plan pricing or availability at any time. Some dealers may also chose not to participate in plan pricing Contact your local dealer to determine final pricing.

S11.

EPA estimated city/highway mpg based on base engine/transmission configuration. Actual mileage will vary.

S12.

Towing - Properly equipped.

S13.

For Dealer Ordered vehicles, the vehicle has already been ordered by the dealer and is in the process of being manufactured by the factory. If you are interested in the vehicle marked "Dealer Ordered", contact the dealership for a delivery estimate.

S14. The "estimated selling price" is for estimation purposes only and the figures presented do not represent a price that can be accepted by you. See your local dealer for vehicle availability and actual price. The Estimated Selling Price shown is the Base MSRP plus destination charges and total of options, but does not include service contracts,



insurance or any outstanding prior credit balance. Does not include tax, title or registration fees. It also includes the acquisition fee. For Commercial Lease product, upfit amounts are included.

The "estimated capitalized cost" is for estimation purposes only and the figures presented do not represent an offer that can be accepted by you. See your local dealer for vehicle availability, actual price, and financing options. Estimated Capitalized Cost shown is the Base MSRP plus destination charges and total of options, but does not include service contracts, insurance or any outstanding prior credit balance. Does not include tax, title or registration fees. It also includes the acquisition fee. For Commercial Lease product, upfit amounts are included.

S15.The "amount financed" is for estimation purposes only and the figures presented do not represent an offer that can be accepted by you. See your local dealer for vehicle availability, actual price, and financing options. Estimated Amount Financed is the amount used to determine the Estimated Monthly Payment. It is equal to the Estimated Selling Price of the vehicle less Down Payment, Available Incentives and Net Trade-in Amount.

The "adjusted capitalized cost" is for estimation purposes only and the figures presented do not represent an offer that can be accepted by you. See your local dealer for vehicle availability, actual price, and financing options. Estimated Adjusted Capitalized Cost is the amount used to determine the Estimated Monthly Payment. It is equal to the Estimated Capitalized Cost less Down Payment, Available Incentives, and Net Trade-in Amount.

S16.

Total MSRP is Base MSRP plus options, destination and delivery charges. Excludes taxes, title, and registration fees.

S17.

Destination Charges are associated with getting the vehicle from the manufacturer to the dealership. Prices listed are MSRP and are based on information updated on this website from time to time.

S18.Acquisition Fee is a charge paid by the lessee to Ford Credit to help cover the cost of acquiring and servicing the account.

Note2.

For Manufacturer Specific Disclosures See Below

1.

Starting MSRP excludes destination/delivery charge, taxes, title and registration. Optional equipment not included. Starting A, Z and X Plan price is for qualified, eligible customers and excludes document fee, destination/delivery charge, taxes, title and registration. Not all vehicles qualify for A, Z or X Plan. All Mustang Shelby GT350 and Shelby GT350R prices exclude gas guzzler tax.

2.

EPA-estimated city/hwy mpg. See fuelconomy.gov for fuel economy of other engine/transmission combinations. Actual mileage will vary. MPGe is the EPA equivalent measure of gasoline fuel efficiency for electric mode operation.

DISCLOSURES ()





Quotation

Driving a Better Way™
chargepoint.com

Sales Representative: Jacob Nino
E-Mail: jacob.nino@chargepoint.com
Telephone:

Quote Number: Q-67499-1
Date: 8/22/2019
Expires On: 9/21/2019

Primary Contact: Shelby Leighton

Bill To Address
Nez Perce Tribe
17500 Nez Perce Rd
Lewiston Idaho 83501
United States

Ship To Address
Nez Perce Tribe
17500 Nez Perce Rd
Lewiston Idaho 83501
United States

Product Name	Product Description	Qty	Unit Price	Total Price
CPE250C-CCS1-CHD	CP Express 250 Station (50 kW) - includes Express 250 Station, 2x Power Modules, 1x CCS1 cable, 1x CHAdeMO cable, North America Modem/SIM, cUL and UL listed, requires CPE250-CMT-IMPERIAL in US, CPE250-CMT-METRIC in Canada. CPE250-CMT-IMPERIAL/METRIC not included.	1	USD 35,800	USD 35,800
CPE250-CMT-IMPERIAL	Concrete Mounting Template used for the base mounting for the CPE250 and Express Plus Stations and is used to align conduits and mounting bolts. This template is to be installed into the foundation before the concrete pad is poured. Imperial Units. Included with the CPE250. Required for CPE200 swap to CPE250. If replacement CMT is needed, order CPE250-CMT-IMPERIAL-RP	1	USD 0	USD 0
CPCLD-COMMERCIAL-DC-1	1yr Prepaid, DC, Commercial Cloud Plan. Includes Secure Network Connection, On-going Station Software updates, Station Inventory, 24x7 Driver Support, Host Support, Session Data and Analytics, Fleet Vehicle Management and Integration, Fleet Access Control, Valet Dashboard, Power Management (Circuit, Panel, Site Sharing), Scheduled Charging, Driver Access Control, Pricing and Automatic Funds Collection, Waitlist, Videos (on supported hardware).	1	USD 560	USD 560
CPSUPPORT-ACTIVE	Initial Station Activation & Configuration Service includes activation of cloud services and configuration of radio groups, custom groups, connections, access control, visibility control, pricing, reports and alerts. One time initial service per station.	1	USD 349	USD 349



Product Name	Product Description	Qty	Unit Price	Total Price
CPEXPRESS-SITEVALID	Customer works with their own contractor to perform the construction and station installation. CPEXPRESS-SITEVALID is used to validate that a customer installation has been performed per ChargePoint published requirements. The on-site validation of electrical capacity, transformers, panels, breakers, wiring, cellular coverage and that the station installation meets all ChargePoint published requirements and local codes. A site is defined as a group of stations all connected to the same gateway station. To be used when the customer is not using an O&M Partner or self-validating Channel Partner to install their stations. Note that a failed Site Validation will incur a second validation fee to repeat the validation after the site deficiencies are corrected. A successful Site Validation is a prerequisite to purchase ChargePoint Assure. CPEXPRESS-SITEVALID is priced per power module.	2	USD 300	USD 600
EXPRESS-ASSURE1	1yr prepaid Assure Plan priced per power module	2	USD 2,100	USD 4,200

Quote Total: USD 41,509.00
Shipping and Handling: USD 1,100.00
Grand Total: USD 42,609.00

Quote Acceptance

- All pricing is confidential between Customer and ChargePoint.
- All prices are FCA ChargePoint warehouse(s).
- Customer to be invoiced at time of shipment.
- Sales tax in applicable states and shipping costs will be applied to this quote at time of invoicing.
- All invoices are Net 30 days.
- Credit Checks are required for new customers.
- Pricing does not include installation or mounting services unless specifically quoted above.
- Additional Purchase Terms and Conditions can be found at <http://www.chargepoint.com/termsandconditions>
- Purchaser confirms that the shipping and billing information provided in the Quotation is accurate for ChargePoint's shipping and invoicing purposes.

By signing this quote I hereby acknowledge that I have the authority to purchase the product detailed on this document on behalf of my organization. Furthermore, I agree to the above terms and conditions and that this signed quote shall act as a purchase order.